



VERTICAL MACHINING CENTER

Compact, Durable, Powerful,
Strong and Accurate



sales@microdynamicsusa.com
www.microdynamicsusa.com



Website



Youtube



Download

MD202605 SAE

MEGA TERA

 SERIES

MICRO DYNAMICS VERTICAL MACHINING CENTER

The MEGA/TERA Series has been designed with the latest in technology being utilized throughout the machine with productivity in mind. From its EtherNet/IP architecture for easy automation and integration into systems and cells, to its Motion Control for fast and smooth operations used in all industries, the MEGA/TERA Series has quickly become one of the industries leading machine tool lines of Vertical Machining Centers.

Micro Dynamics Vertical Machining Center Line opens a new era in multi-purpose and versatile machining centers. Compact, durable, powerful, strong and accurate, the MEGA/TERA Series starts a revolution in the market: the smallest C-frame machines provide powerful and precise results for manufacturers of dies and molds, aerospace, automotive, semi-conductor, job shops and general machine sectors.

MEGA / TERA SERIES STANDARD EQUIPMENT

BUILT-IN SPINDLE

**40 Taper
CAT 40**



- 15,000 rpm (std) ~ 24,000 rpm
- 41 HP (std) ~ 47 HP

**50 Taper
CAT 50**



- 12,000 rpm
- 45 HP

Optional BT / HSK

DYPEC[®] THERMAL COMPENSATION

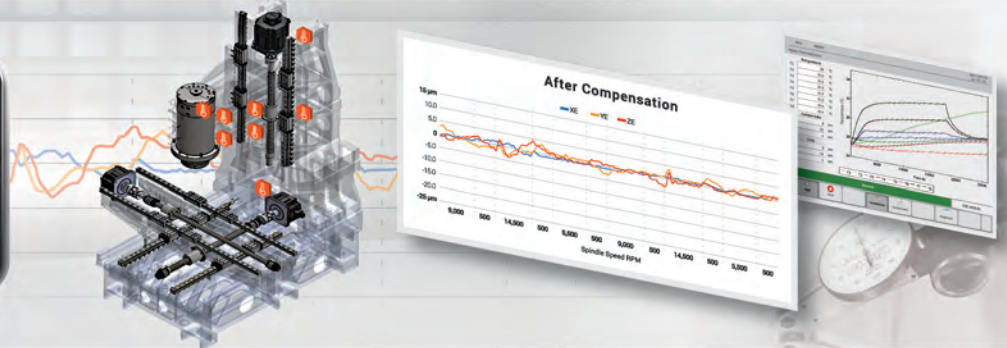

MICRO DYNAMICS HMI

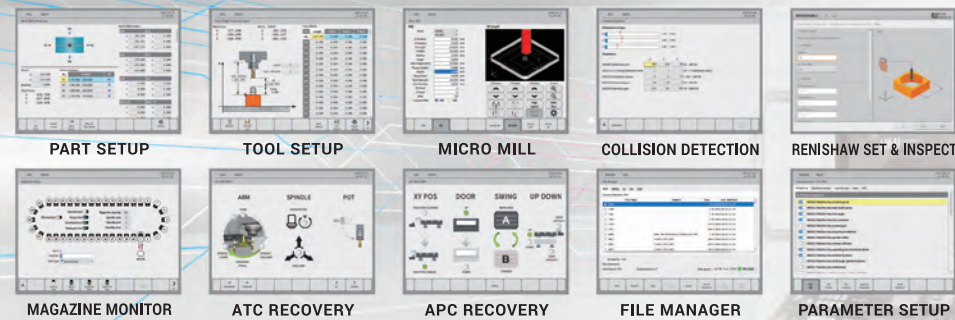

RAPID TRAVERSE
2,047 ipm

LOOK AHEAD
5,400 block

TOOL TO TOOL
1.2 sec



POWERFUL

Integrated Micro Dynamics Built-in Spindle.

FAST

Mitsubishi CNC M830VW / CNC M850VW.(*)

RELIABLE

Highest quality mechanical and electrical components.

THERMAL COMPENSATION

DYPEC[®] - Dynamic Predictive Error Compensation.

MICRO MILL[®]

Conversational programming.

PC BASED HMI

Allows user friendly functions.

COMPACT

Design with small footprint.

STRONG

FC300 Meehanite[®] casting.

INTEGRATED AUTOMATION

EtherNet/IP networked I/O.

COLLISION DETECTION

Machine stops if a collision is detected in all axis.

RIGID TAP

Up to 6,000 rpm.

15" / 19"(*) TOUCHSCREEN

Ergonomically friendly.

MICRO DYNAMICS BUILT-IN SPINDLE

- Powerful integrated 40 Taper and 50 Taper dual contact spindle. (CAT / BT / HSK)
- Standard 15,000 rpm with permanent grease.
- Optional 20,000 rpm and 24,000 rpm with air-oil lubrication.
- ATE Motor (German made) is integrated with hybrid ceramic angular contact bearings.
- Micro Dynamics drawbar has been rigorously tested to sustain more than 2 million cycles.
- CTS (Coolant Through Spindle) designed to sustain up to 100 bar (1,500 psi).(*)

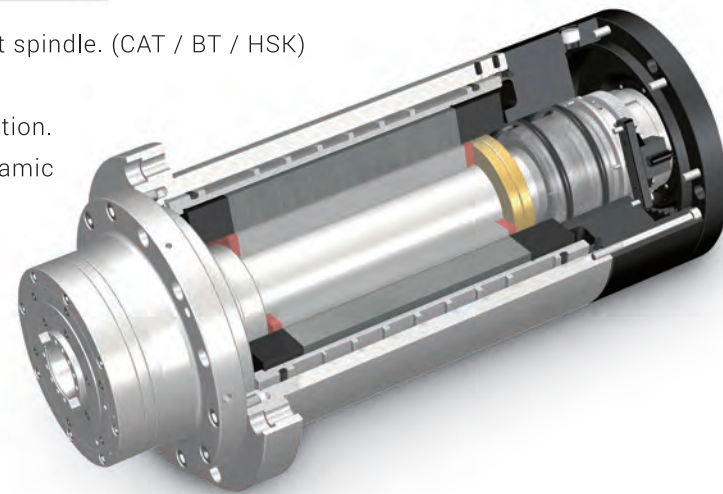

(*) CTS preparation is standard equipment. CTS system is optional.

MULTIPURPOSE APPLICATIONS

- For all applications, from heavy duty to high speed machining.
- Highest productivity under any conditions and complexities.

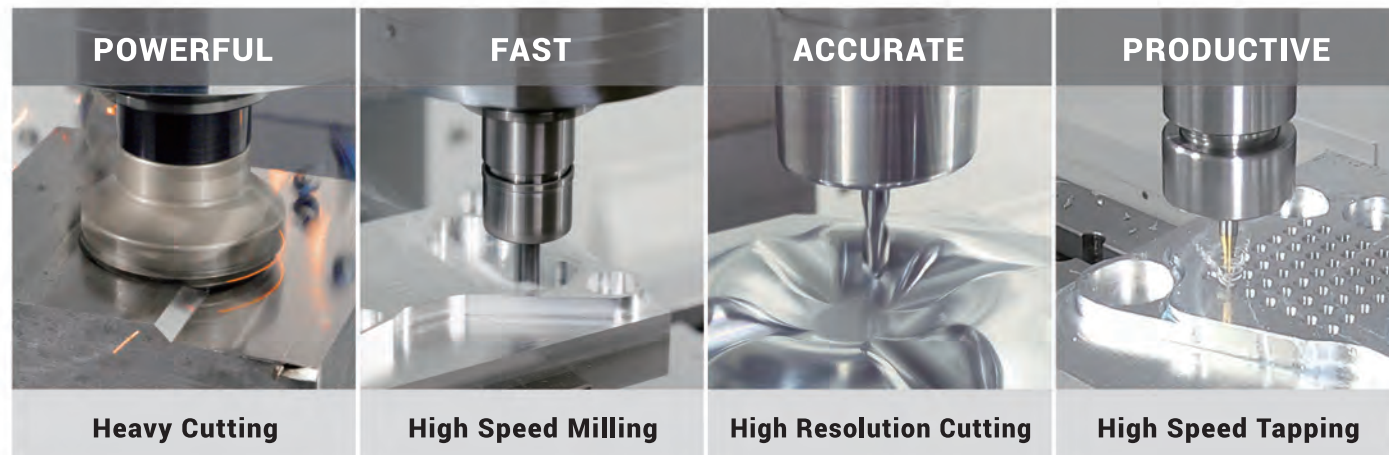

MAXIMUM PRODUCTIVITY

All Micro Dynamics spindles are built with all shelf standard bearings which can be replaced without removing the rotor. This makes all machines simple and fast to maintain. Rebuild costs are very low due to the availability of the parts and the short service time.



Service Door

Headstock service door to facilitate access is standard on all models.



Coolant Through Spindle (opt) Air Through Spindle (opt)

- 20-Bar (290 psi)
- 40-Bar (580 psi)
- 70-Bar (1,000 psi)

40 TAPER DUAL CONTACT (CAT / BT / HSK-63A)

Standard 15,000 rpm

Power	41 HP
Torque	104 ft-lb
Acc. 0 – 12K	1.5 sec
Dec. 12K – 0	1.8 sec

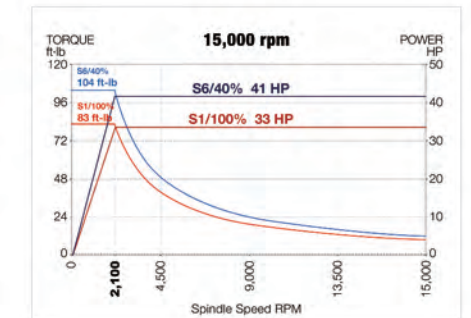

Option 20,000 rpm

Power	47 HP
Torque	88 ft-lb
Acc. 0 – 12K	1.5 sec
Dec. 12K – 0	1.8 sec

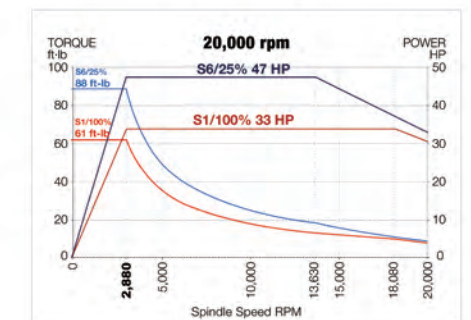

Option 24,000 rpm (*)

Power	47 HP
Torque	88 ft-lb
Acc. 0 – 15K	1.7 sec
Dec. 15 – 0	2.0 sec

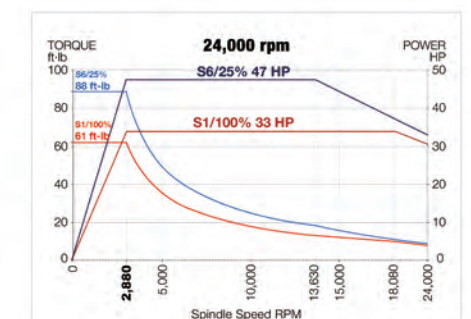

(*) Standard HSK-63A

50 TAPER DUAL CONTACT (CAT / BT / HSK-100A)

Standard 12,000 rpm

Power	45 HP
Torque	420 ft-lb
Acc. 0 – 8K	1.8 sec
Dec. 8K – 0	2.5 sec

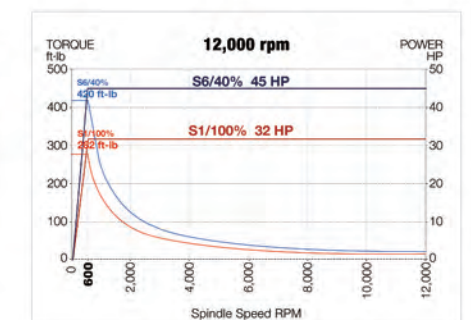

STRUCTURE

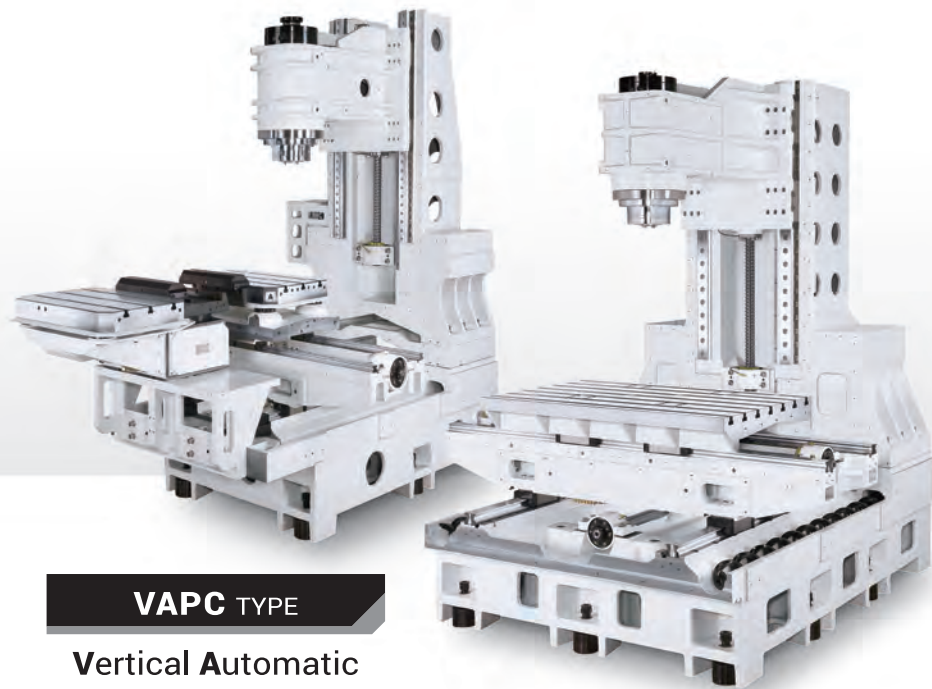

VAPC TYPE

**Vertical Automatic
Pallet Changer**

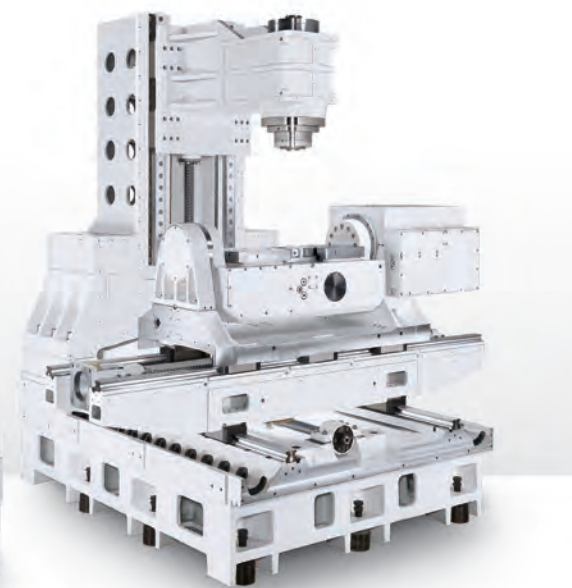

VT TYPE

Vertical Trunnion

V TYPE
Vertical Machining

The heavily ribbed structure is made of FC300 Meehanite® casting that has been FEA analyzed for strength and stability. All castings are designed to reach the maximum level of rigidity for the best machining performance.



Hand Scraping

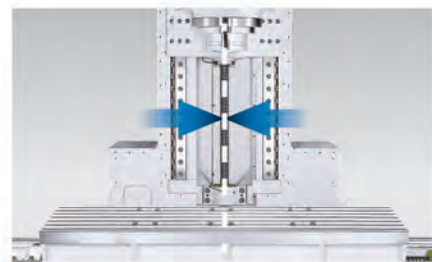

Symmetric Design



Honeycomb Ribbed

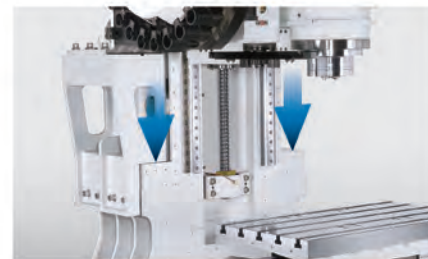

Supporting Shoulders

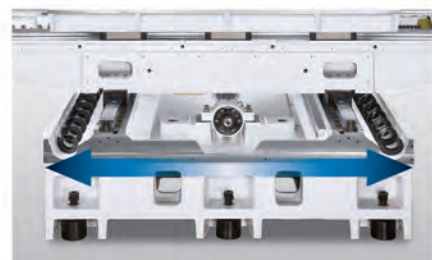

Wide Base



Integrated APC

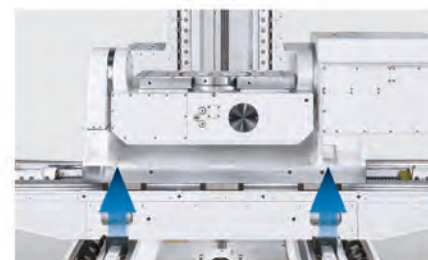

Full Stroke Support

**MEGA
SERIES**

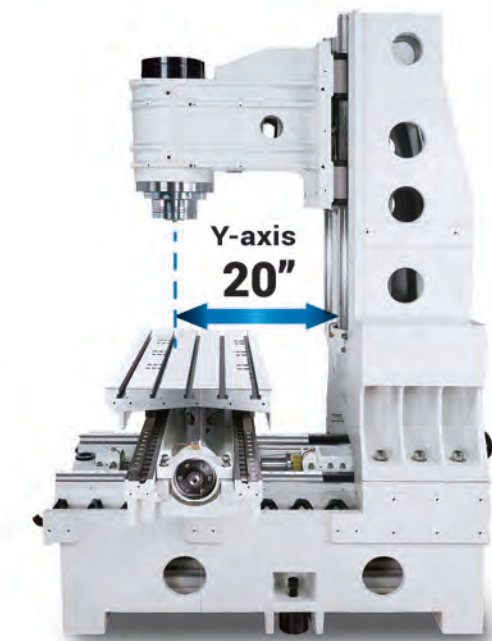
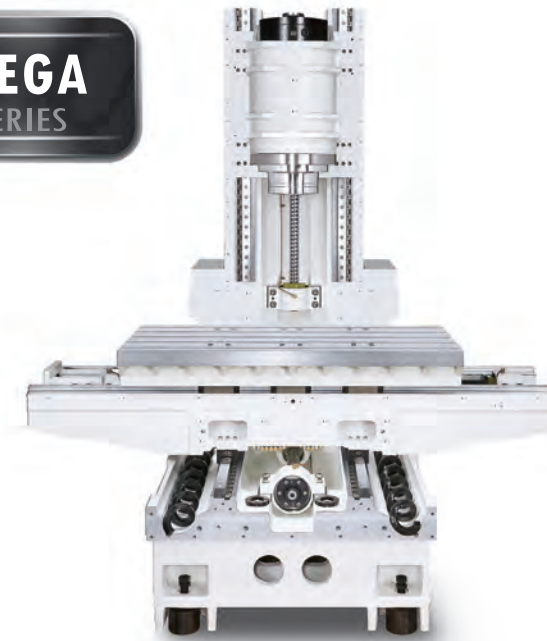

MEGA/TERA represents the two C-frame sizes for the series. The compact frames with the proven design and placement for all the components, makes each model one of the smallest foot-prints in their class.

40 Taper Travel	X	Y	Z
MEGA 30V	30"	20"	20"
MEGA 40V	40"		
MEGA 20VAPC	24"	20"	20"
MEGA 30VT	30"	20"	17.4"

**TERA
SERIES**

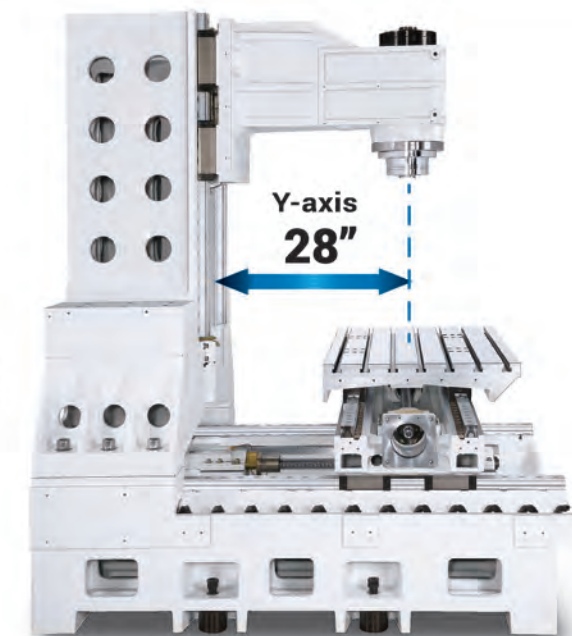

40 Taper Travel	X	Y	Z
TERA 40V	40"		
TERA 50V	50"	28"	25"
TERA 60V	60"		
TERA 50VT	38"	28"	19.7"

50 Taper Travel	X	Y	Z
TERA 50V/50	50"	28"	25"
TERA 60V/50	60"		
TERA 50VT/50	38"	28"	19.7"

AUTOMATIC TOOL CHANGER

The MEGA/TERA Series is equipped with a high-speed double arm tool changer with a 40-tool magazine(*). The magazine is integrated on the machine with an isolated structure, eliminating vibrations to the column, thus improving accuracy and finishes. The multi speed double arm allows the operator to adjust the speed of the tool changes for oversized, heavy tools and probes, to ensure accuracy and reliability. The ATC recovery function in HMI is a standard feature that assists the operator in recovering the position of the arm and the tool.

(* MEGA 30V standard is 30-tool magazine.

HIGH SPEED ATC (40 Taper)

Tool to Tool
1.2 sec

Chip to Chip
2.5 sec

Factory Conditions

Isolated Structure

The tool magazine is integrated to the machine with an isolated structure, eliminating vibrations to the column.

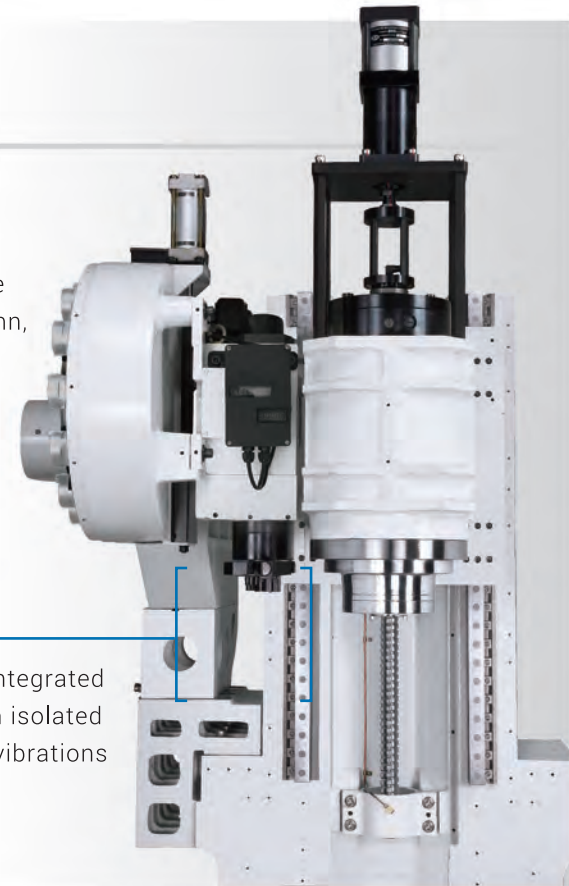

TOOL MAGAZINE



High Speed Tool Magazine

Standard	Option
■ 32 Tools for 50 Taper	■ 30 Tools (TERA 40V)
■ 40 Tools for 40 Taper	■ 60 Tools
(MEGA 30V is 30 Tools)	■ 90 Tools
	■ 120 Tools



Full Cover Magazine

The tool magazine is protected from the machining environment reducing chips and coolant from entering the magazine area.

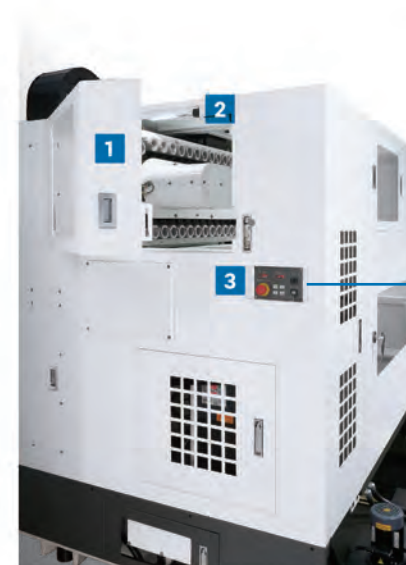

1. ATC Rear Door with Window
2. Magazine Lighting
3. Rear Operation Panel



ATC rear operation panel(*) and door allow access for loading, unloading and inspection of tools while the machine is in operation. Tools can be called up either by tool number or by pocket number. During manual operation the machine will continue the cycle without interruption until ATC door is closed and the key is switched to automatic.

(*) Except 30 tools magazine.

CHIP MANAGEMENT SYSTEM

The chip management system includes base wash, dual augers and chip conveyor, virtually eliminating chip build-up. Coolant falls along the inside perimeter flushing chips down to the dual augers which evacuate chips to the front conveyor. All mounting hardware is bolted from the outside leaving a clean surface for chip evacuation.

EFFECTIVE DESIGN OPTIMIZES CHIP MANAGEMENT

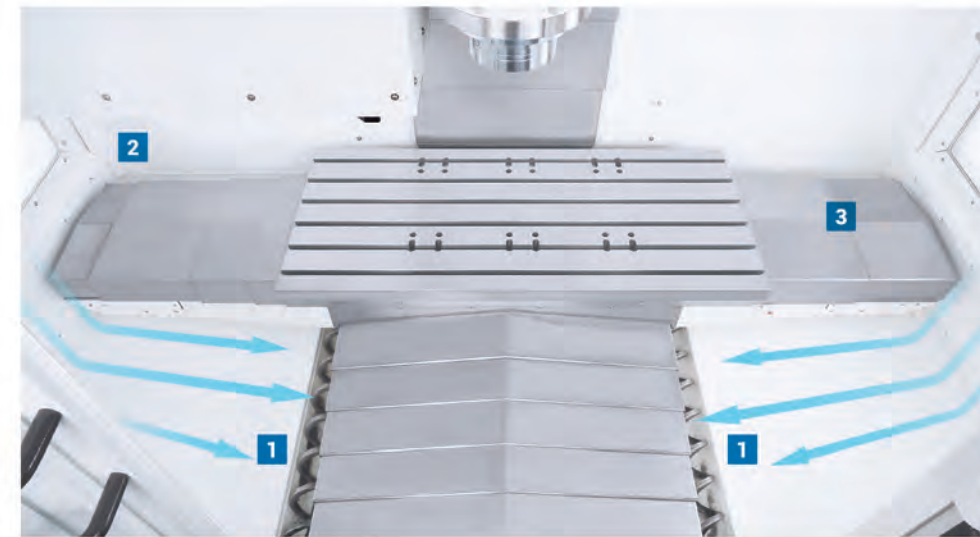

1. Dual augers in the extra-large working area.
2. No blind angle inside chip enclosure.
3. Triple protection on linear guides and ball screws: bottom cover, top cover and telescopic cover.



BOTTOM COVER



TOP COVER

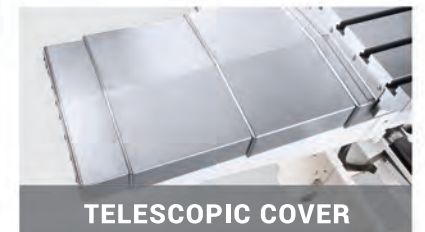

TELESCOPIC COVER

MODULAR COOLANT / CHIP SYSTEM

1. Filter Chip Basket
2. Filter Chip Pan
3. Chip Conveyor
4. CTS Pump Option
5. Base Wash Pump
6. Coolant Pump



REVERSIBLE CONVEYOR

Standard in all MEGA/TERA Series. (except MEGA 20VAPC)
Rear chip conveyor available under request for all models.



ERGONOMICS

WORKING AREA

COMPLY WITH ERGONOMICS PRINCIPLES

Easy setup for operator

MEGA/TERA Series is ergonomically designed for operator and maintenance convenience. The large wide front door can be opened with one hand. There are three LED lights, two in the sides and one over the work area.

The distance from the door to the table is less than 7.9" for easy setup and part loading. The reach for operator access to the spindle is greatly reduced.

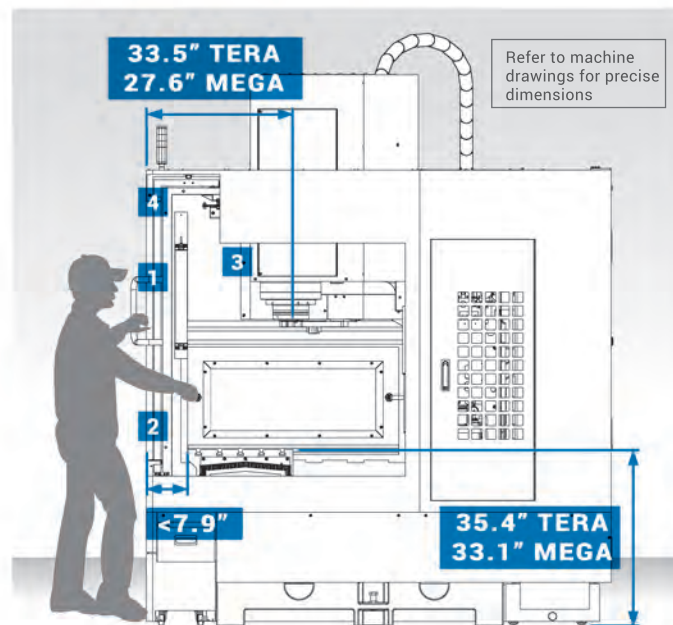

Refer to machine drawings for precise dimensions



1. Synchronized Two-Piece Door

2. Door to Table Less than 7.9"



3. Reduced Distance to Spindle

4. Automatic Lighting

CONTROL PANEL

ADJUSTABLE CONTROL PANEL

Easy to operate panel



- 15" and 19"(*) touchscreen.
- Hard and resistant short travel buttons.
- Micro Dynamics HMI app quick access buttons.
- QWERTY and numerical keyboards.
- Touchpad / Front USB.
- Feedrate, spindle speed, spindle load, and tool number digital display.
- Rapid feedrate override led knob.
- Cutting feedrate override led knob.
- Spindle speed override led knob.
- Mode selection led knob.
- MPG (Manual Pulse Generator).

(*) Optional

The two-axis motion operator panel provides control for flat, tilting, and swivel movements. User can easily adjust the panel's tilt angle and rotation angle to achieve the best viewing angle and comfort, according to personal preferences or the requirements of the work.

FOOTPRINT

MINIMAL FOOTPRINT

Optimize efficiency, cut costs, and boost flexibility with a reduced footprint compared to other vertical machining centers with the same travel.



MICRO DYNAMICS vs. OTHERS

Footprint Space saved

MODEL	MEGA 20VAPC	Others	MODEL	MEGA 30V	Others
X/Y Travel	24" x 20"	22" x 16"	X/Y Travel	30" x 20"	30" x 20"
Footprint Space Saved	46% up		Footprint Space Saved	28% up	
MODEL	MEGA 40V	Others	MODEL	MEGA 30VT	Others
X/Y Travel	40" x 20"	40" x 20"	X/Y Travel	31" x 20"	28" x 20"
Footprint save space	37% up		Footprint Space Saved	23% up	
MODEL	TERA 40V	Others	MODEL	TERA 50V	Others
X/Y Travel	40" x 28"	40" x 26"	X/Y Travel	50" x 28"	50" x 26"
Footprint Space Saved	28% up		Footprint Space Saved	25% up	
MODEL	TERA 60V	Others	MODEL	TERA 50VT	Others
X/Y Travel	60" x 28"	60" x 26"	X/Y Travel	38" x 28"	37" x 31"
Footprint Space Saved	10% up		Footprint Space Saved	38% up	

DYPEC[®] THERMAL COMPENSATION

Dynamic Predictive Error Compensation, corrects position error caused by thermal changes which improves accuracy and part finishes. (resolution 0.1 μm)

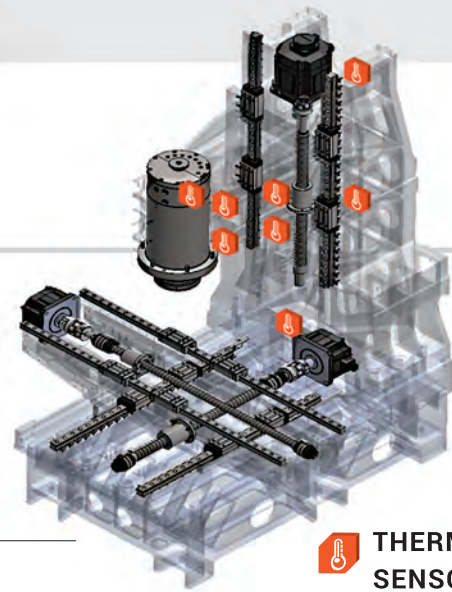

THERMAL SENSOR

THERMAL COMPENSATION PARAMETER SETUP



Continuous monitoring of spindle axial deviation. Long time run test to collect thermal changing data for each individual machine.

48 HOURS TEST

X/Y/Z axis static error in microns before and after DYPEC[®] compensation

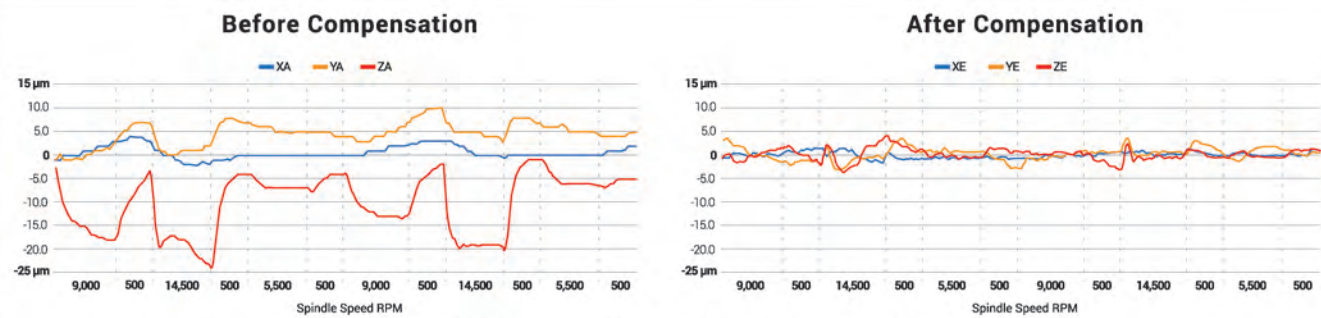

DYPEC[®] "Real Time" Thermal Compensation data

THERMAL COMPENSATION FUNCTION TEST

DYPEC[®] mirror milling with ball end mill

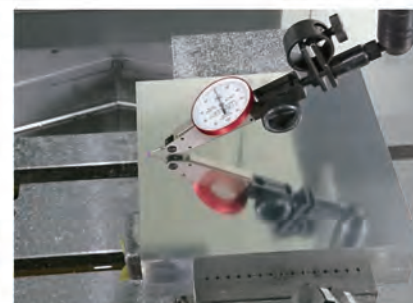
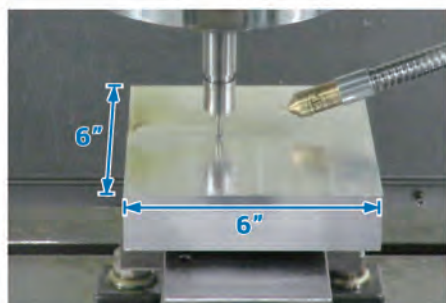

Tools	Ø0.23" nose ball
Material	6061 Aluminum
Feed Rate	59 ipm
Spindle Speed	15,000 rpm
Machining Time	2 h 24 min
Total Deviation < 2 μm	

ACCURACY

Circle, diamond, square cutting test is done on all Micro Dynamics machines prior to shipment at 59 ipm with a maximum tolerance under 5 microns linear.

- XY, XZ, and YZ Double Ball Bar Test Results at 59 ipm under 5 microns.
- X, Y, and Z Axis Laser Compensation under 5 microns.
- 4th and 5th Axis Laser Compensation under 10 arcsecs.



DOUBLE BALL BAR TEST

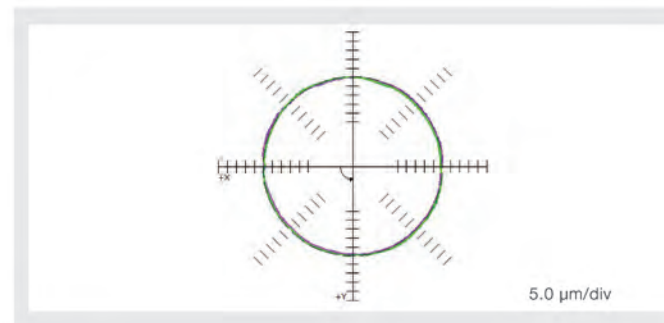

E.g. XY Double Ball Bar Test Results under 5 microns.

Factory Conditions

16% Squareness	6.3 μm/m
16% Backlash X	← -0.3 μm → 0.9 μm
13% Reversal spikes X	← -0.8 μm → -0.4 μm
12% Cyclic error Y	↑ 0.8 μm ↓ 0.7 μm
10% Lateral play X	← 0.8 μm → 0.4 μm
Circularity	2.7 μm

LASER COMPENSATION

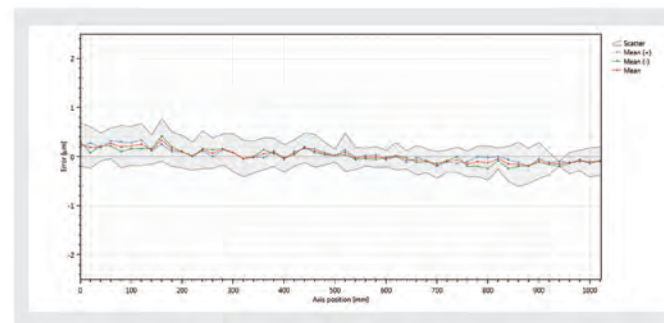

E.g. X Axis Laser Compensation under 5 microns.

Factory Conditions

Linear X - Analysis features	VDI 3441 Value (μm)
Name	Value (μm)
Maximum reversal (U max)	0.2
Maximum scatter (Ps max)	0.8
Positional uncertainty (P)	1.4
Positional deviation (Pa)	0.5
Mean reversal	0.1
Mean scatter (Ps mean)	0.5

(Without scales)

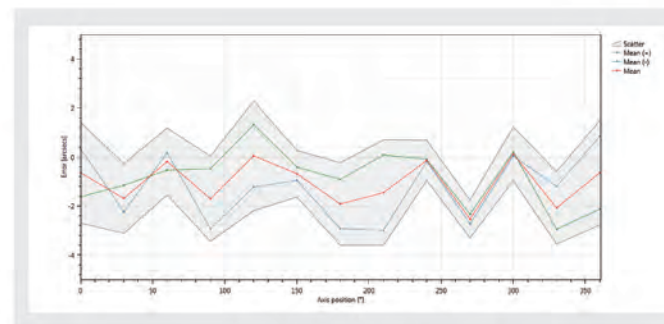

E.g. 5th Axis Laser Compensation under 10 arcsecs.

Angular C - Analysis features	VDI 3441 Value (arcsecs)
Name	Value (arcsecs)
Maximum reversal (U max)	3.1
Maximum scatter (Ps max)	2.1
Positional uncertainty (P)	5.9
Positional deviation (Pa)	2.7
Mean reversal	1.5
Mean scatter (Ps mean)	1.5

(Without scales)

Y Position	0.000	mm
X Length	50.000	mm
Y Width	50.000	mm
Radius	2.000	mm
Angle	0.000	
Safe Height (G00)	10.000	mm
Plunge Height	3.000	mm
Depth	-1.000	mm



MICRO DYNAMICS HMI

The Windows® embedded HMI CNC gives the user the ability to create or add apps to make it flexible to operate and automate the machine. Operator can load, run or edit any program from any device: internal HMI memory, PC hard drive or external USB device.

AUTO PART SETUP with HARD PROBE



X, Y, Z work offset can be measured with a hard probe.



PART SETUP
Fast and easy function for manually or automatically setup the part.



TOOL SETUP
Fast and simple function for manually or automatically measure all the tools.

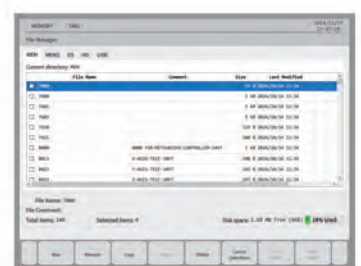

FILE MANAGER
Transfer files from USB, NC memory or Hard Drive in one click.

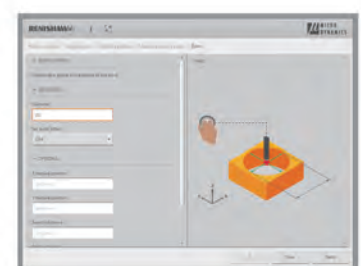

RENISHAW SET & INSPECT
Simple, intuitive and easy-to-use on machine probing app.

COLLISION DETECTION

Machine stops if a collision is detected in all axis.



Collision detection is a Micro Dynamics function that allows the operator to setup the maximum load in all motors. If any motor exceeds the maximum load, the function will detect a collision and will stop the machine in all axis.

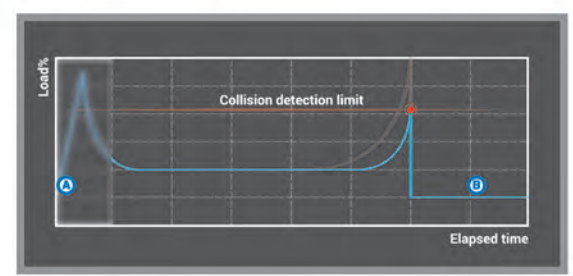
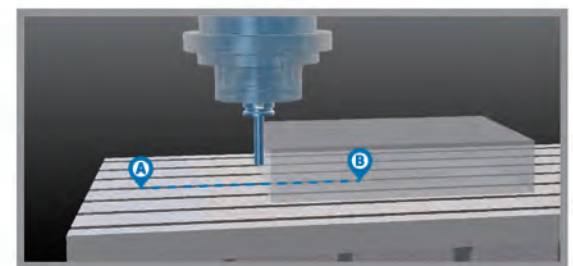

Please scan the QR code to watch the video.

The MEGA/TERA Series features Mitsubishi CNC M830VW / CNC M850VW(*) Control which is well suited to high-speed, high-accuracy machining and multi-axis, multi-part system control. Mitsubishi's tool path graphics verification makes it easier for end users to check G-Code program before machining.

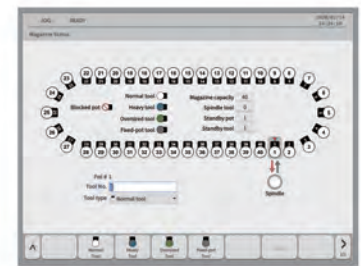

MAGAZINE MONITOR
Load, unload and manage all tools in one screen.



MICRO MILL®
Conversational programming allows any operator to easily perform milling and drilling operations while creating G-Code and post to MDI or main memory.



ATC RECOVERY function allows the operator to recover the tool changer.



APC RECOVERY function allows the operator to recover the pallet changer.



MICRO DYNAMICS CONTROL SYSTEM FEATURES

- Mitsubishi CNC M830VW / CNC M850VW(*)
- 15" / 19"(*) Touchscreen display.
- 5,400 Block Look Ahead.
- 60 GB Data Server.
- 1,000 Programs in editing memory.
- 999 Sets in tool compensation.
- DXF import.
- 54 Sets work offsets.
- 400 Sets tool life management.
- 8,000 Sets macro variable.
- 64 Bit microprocessor.
- 2,048 KB Program memory.
- Main and subprograms can be edited and run as one file.
- Programs can be run from the front side USB or the hard drive.
- 3D circular interpolation.
- G-Code guidance.
- Helical interpolation.
- NURBS interpolation.(**)
- Programmable in-position check.
- Scaling.
- Simple programming (NAVI mill conversational programming).
- 4G SSS Control (Super Smooth Surface).
- Tolerance control.
- Spiral / conical interpolation.
- Tool Center Point Control.
- 3D tool radius compensation.
- Workpiece position offset for rotary axis.
- Inverse time feed.
- Polar coordinate command.
- Upgradable to 5 axes simultaneous control.(**)

(*) Optional (**) for authorized regions

MEGA 20VAPC

Dual pallet changer MEGA 20VAPC is designed for high production. The servo driven pallet changer switches tables in 8.5 sec. With the APC recovery function in the HMI the operator can easily perform maintenance of the pallet changer.

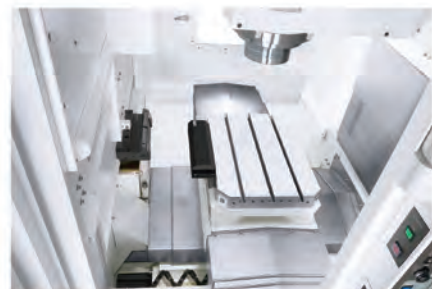
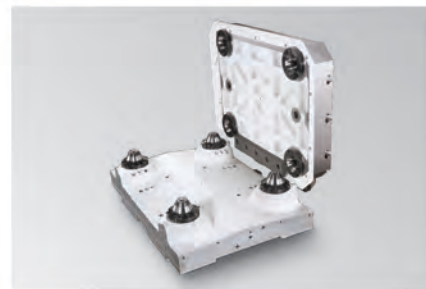

Table Size: 22" x 15.7"



Servo driven pallet changer
Switches tables in 8.5 sec



Pressurized cones
Repeatability 0.00016"

AUTOMATION AND MULTI-AXIS

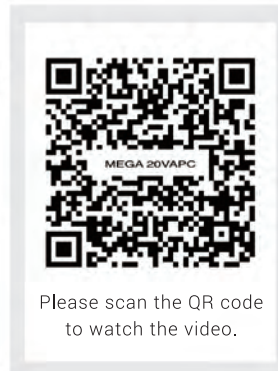
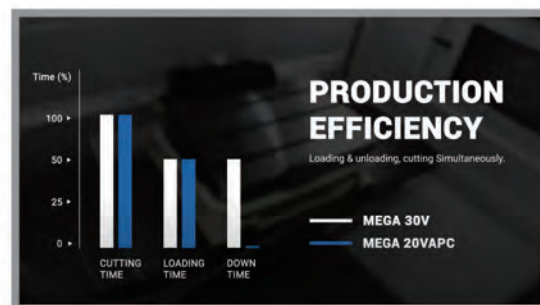

MEGA 30VT / TERA 50VT



The MEGA 30VT and TERA 50VT are Micro Dynamics's five-axis trunnion (4+1) table machines with hydraulic brakes. The design allows the user to load three vises or can be used as a 19.7" x 11.8" work table with a 8.7" diameter face plate in MEGA 30VT and 28.3" x 15.7" work table with a 12.6" diameter face plate in TERA 50VT.

For automation the through hole of the rotary table allows for the plumbing of hydraulics, pneumatics or other devices. A true five-axis simultaneous version is available as an option.



Rotary axis motion ranges

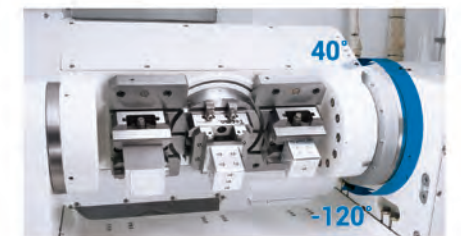

Tilting axis motion ranges

COMPLETE PROCESS IN 1 CYCLE



Machine 6 Sides In One Load

- Left vise: cut dove tail.
- Central vise: 5-side machining.
- Right vise: finish dove tail.

TRUNNION TABLE FACE PLATE

MODEL	Standard	Option (Field interchangeable)	
	Ø8.7"	Ø11.8"	Ø13.8"
MEGA 30VT			
	Ø12.6"	Ø19.7"	Ø24.8"
TERA 50VT			
	Ø12.6"	Ø19.7"	Ø24.8"

MACHINING CAPACITY

40 TAPER BUILT-IN SPINDLE ON 1050 STEEL Factory Conditions

FACE MILL		MATERIAL REMOVAL	SPINDLE LOAD
TOOL	2.48"	46.7 cu in/min	87%
Cut (Width x Depth)	1.97" x 0.24"		
Feedrate	100 ipm		
Spindle Speed	2,173 rpm		

END MILL		MATERIAL REMOVAL	SPINDLE LOAD
TOOL	1.26"	22.5 cu in/min	47%
Cut (Width x Depth)	1.26" x 0.19"		
Feedrate	91 ipm		
Spindle Speed	3,800 rpm		

DRILL		MATERIAL REMOVAL	SPINDLE LOAD
TOOL	1.77"	50.9 cu in/min	90%
Cut (Depth)	1.38" mm		
Feedrate	21 ipm		
Spindle Speed	2,100 rpm		

TAP		MATERIAL REMOVAL	SPINDLE LOAD
TOOL	1.3" x 0.12"	-	46%
Feedrate	15 ipm		
Spindle Speed	128 rpm		

50 TAPER BUILT-IN SPINDLE ON 1050 STEEL Factory Conditions

FACE MILL		MATERIAL REMOVAL	SPINDLE LOAD
TOOL	6.29"	45.8 cu in/min	97%
Cut (Width x Depth)	3.93" x 0.19"		
Feedrate	59 ipm		
Spindle Speed	450 rpm		

END MILL		MATERIAL REMOVAL	SPINDLE LOAD
TOOL	1.26"	22.5 cu in/min	20%
Cut (Width x Depth)	1.26" x 0.19"		
Feedrate	91 ipm		
Spindle Speed	3,800 rpm		

DRILL		MATERIAL REMOVAL	SPINDLE LOAD
TOOL	3.15"	49.1 cu in/min	94%
Cut (Depth)	1.97"		
Feedrate	6 ipm		
Spindle Speed	800 rpm		

TAP		MATERIAL REMOVAL	SPINDLE LOAD
TOOL	1.89" x 0.19"	-	63%
Feedrate	17 ipm		
Spindle Speed	86 rpm		

FACTORY TEST - 40 TAPER

Micro Dynamics standard factory tests for all models includes the circle, diamond, square cutting test, as well as milling, drilling, tapping and the heavy milling test.



Tool	1.97" End Mill
Material	1050 Steel
Cutting Width	0.87"
Cutting Depth	0.28"
Feedrate	28 ipm
Spindle Speed	1,100 rpm
Load	40%

FACTORY TEST - 50 TAPER

Micro Dynamics standard factory tests for all models includes the circle, diamond, square cutting test, as well as milling, drilling, tapping and the heavy milling test.



Tool	1.97" End Mill
Material	1050 Steel
Cutting Width	1.18"
Cutting Depth	0.39"
Feedrate	59 ipm
Spindle Speed	2,000 rpm
Load	47%

MEGA 30V



MACHINE DIMENSIONS

Unit: inch

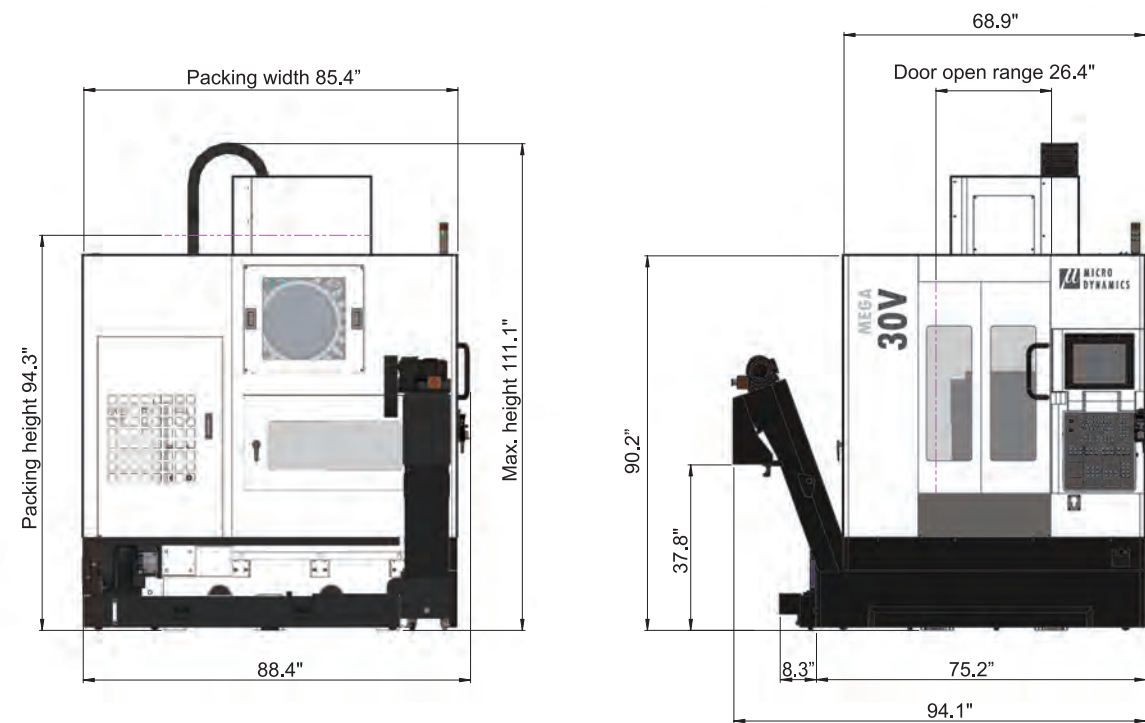

Unit: inch

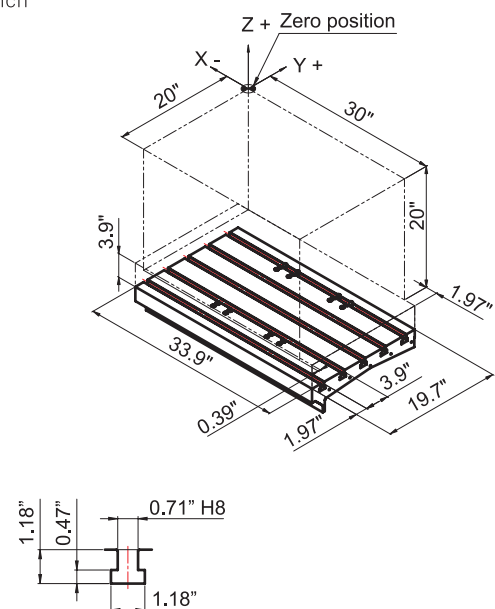

Unit: inch

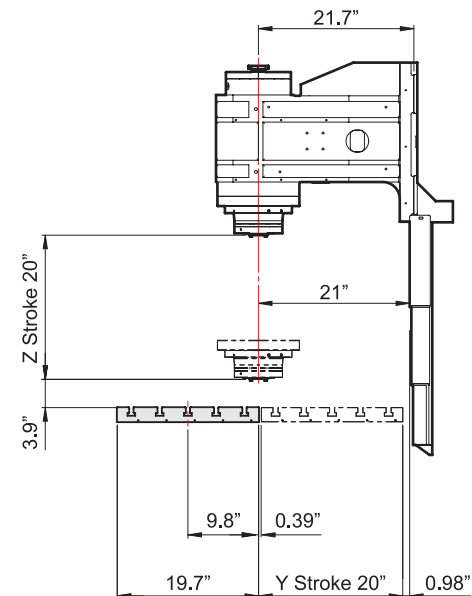

MEGA 40V



MACHINE DIMENSIONS

Unit: inch

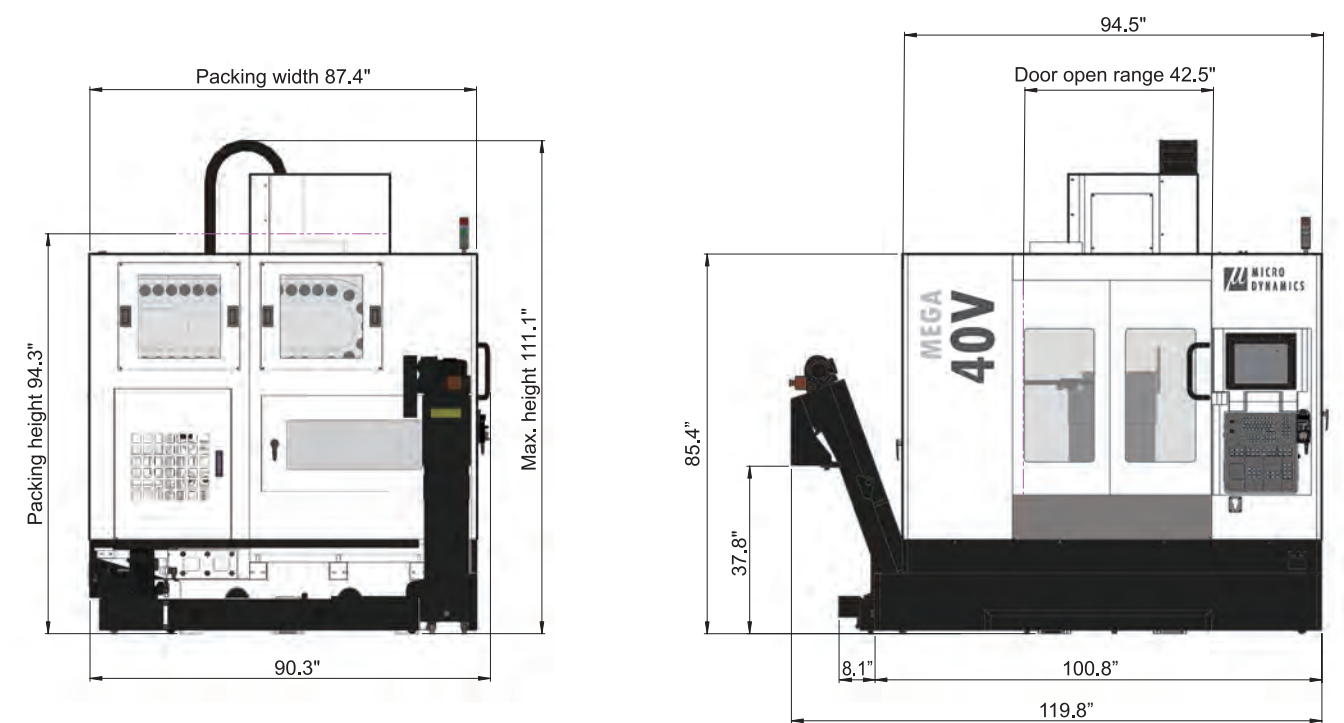

Unit: inch

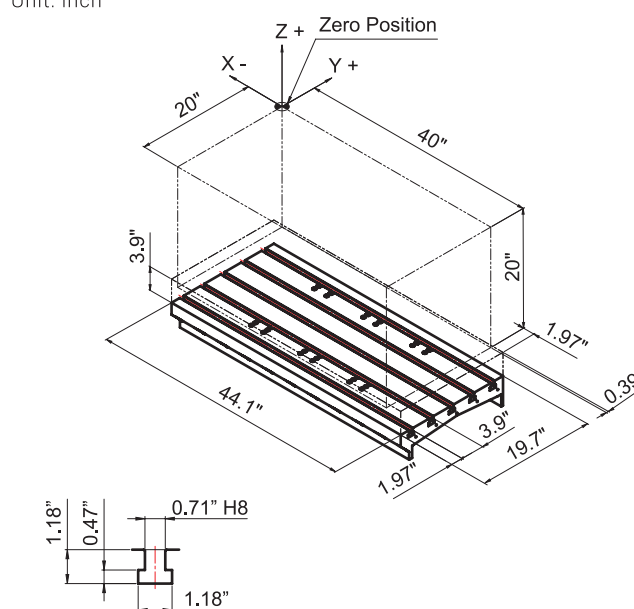

Unit: inch

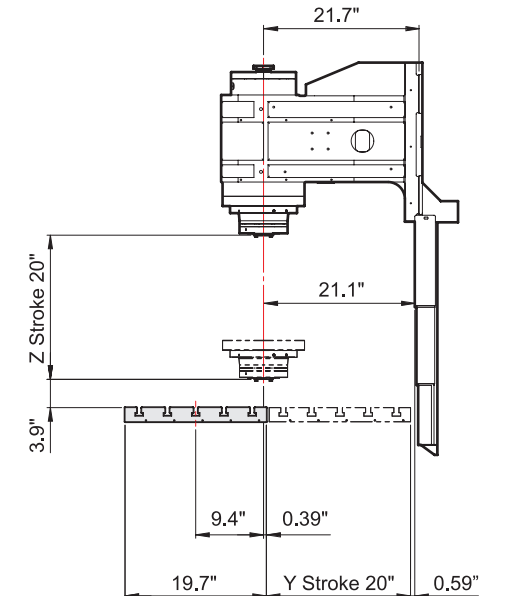

MEGA 20VAPC



MACHINE DIMENSIONS

Unit: inch

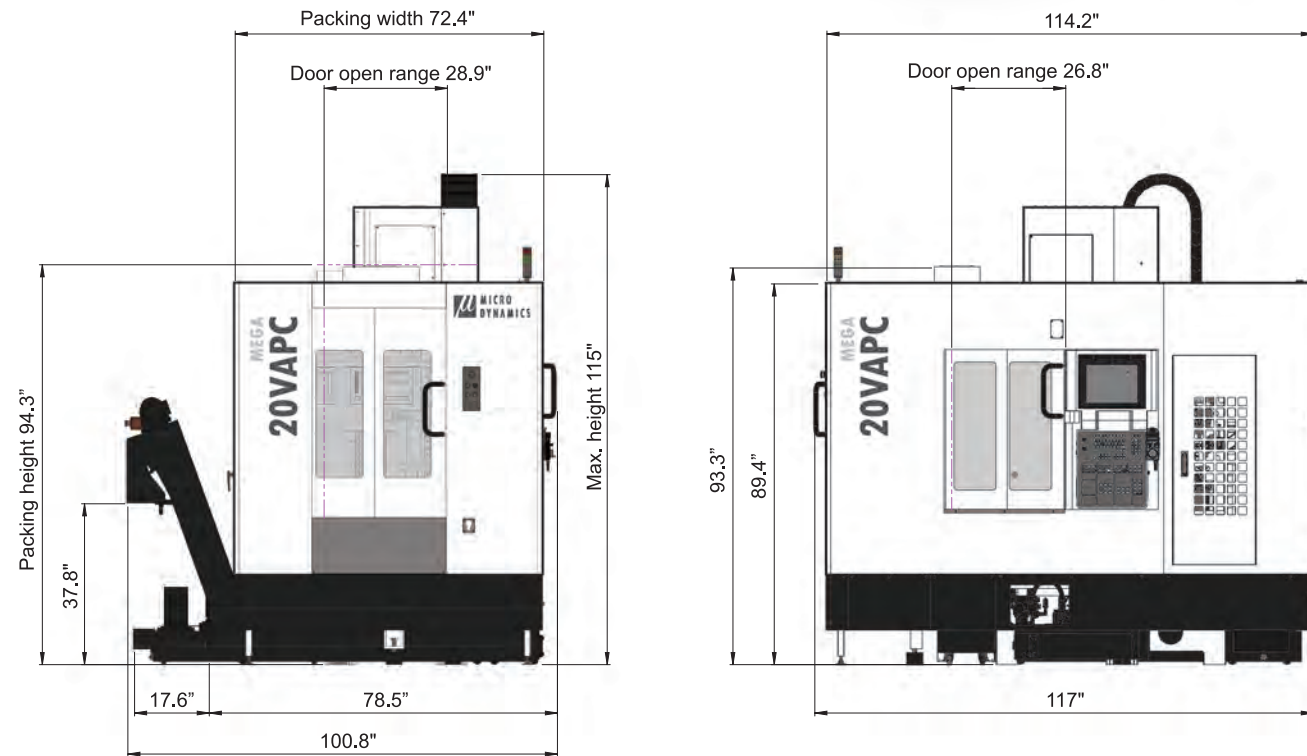

Unit: inch

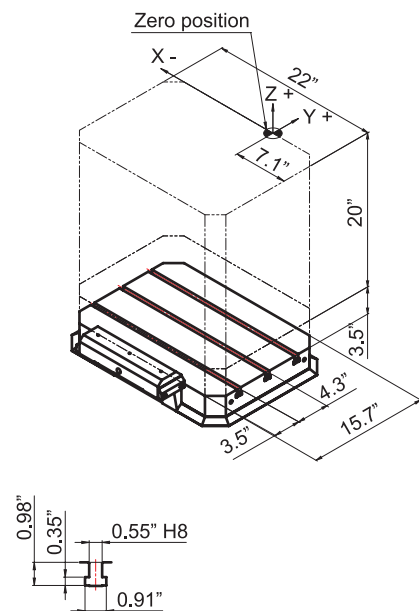

Unit: inch

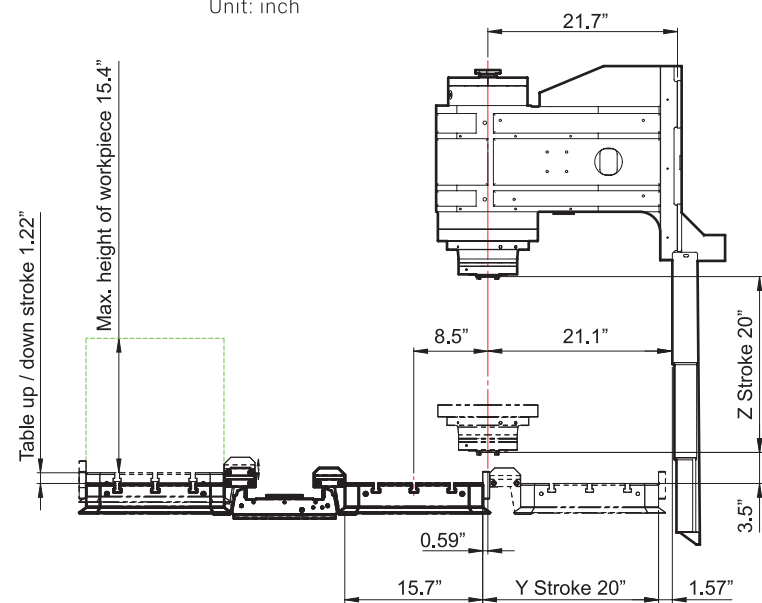

MEGA 30VT



MACHINE DIMENSIONS

Unit: inch

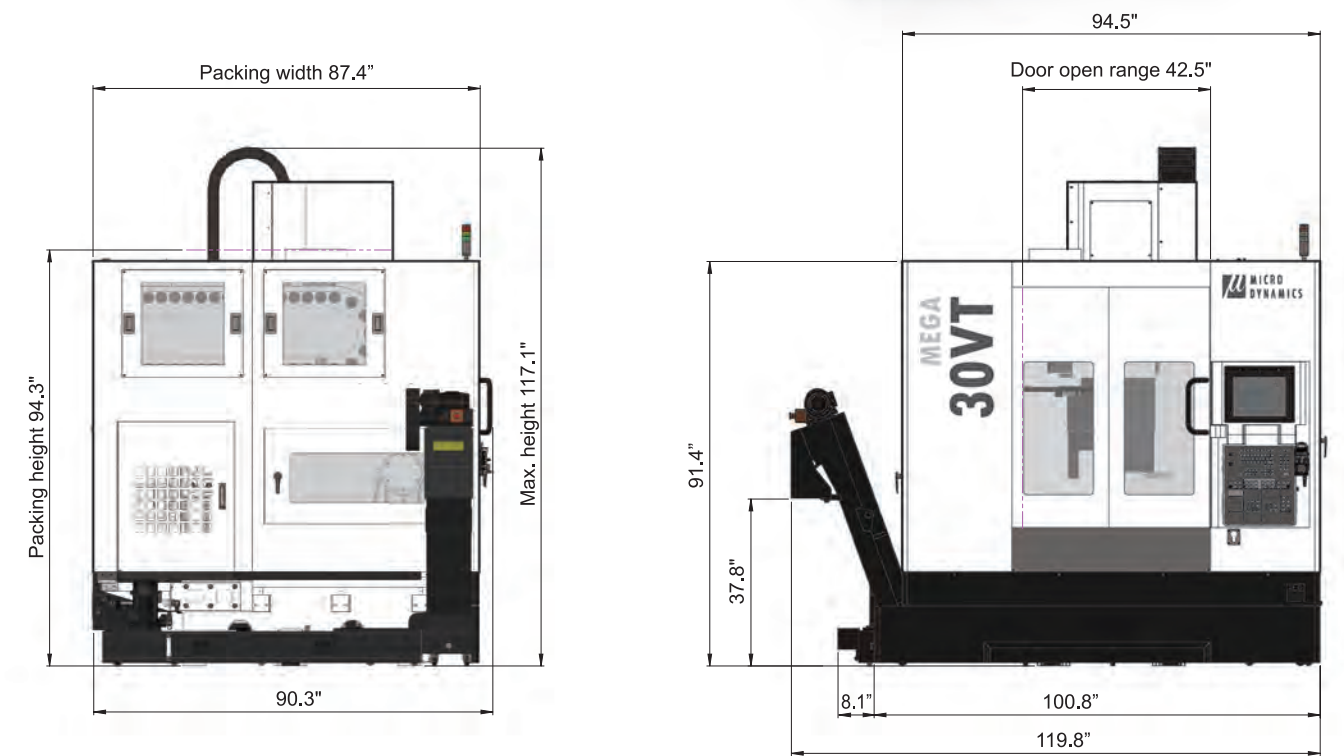

Unit: inch

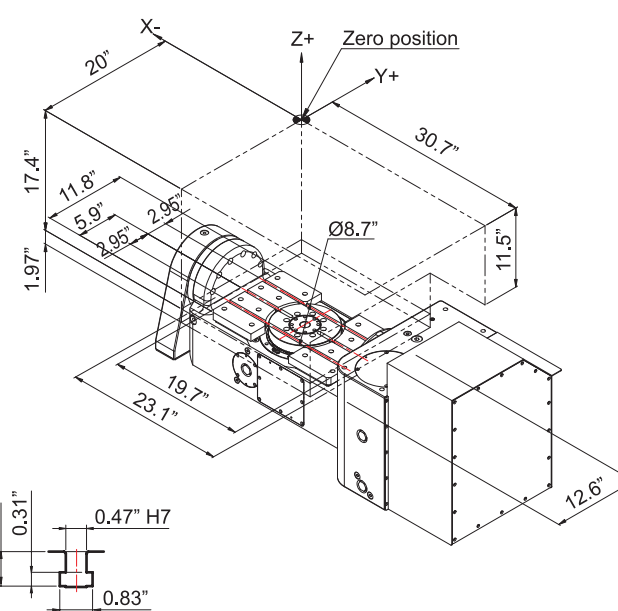

Unit: inch

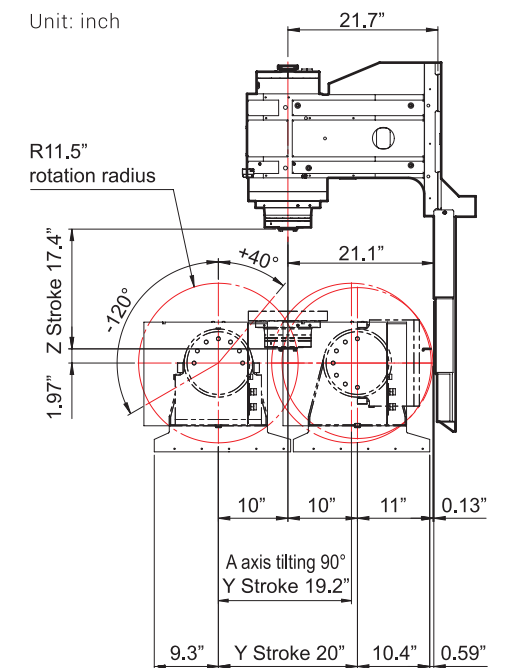

* Ø11.8" and Ø13.8" face plate visit www.microdynamicsfa.com

TERA 40V



MACHINE DIMENSIONS

Unit: inch

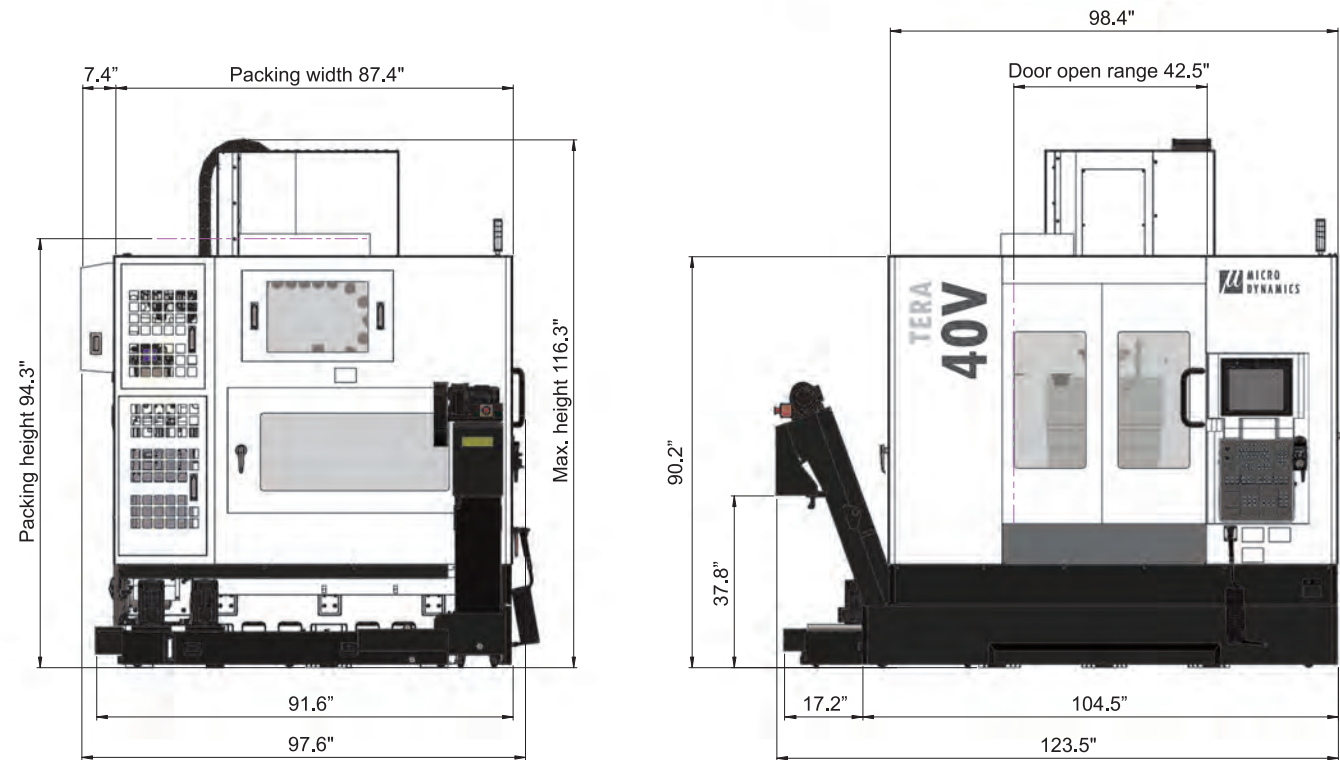

Unit: inch

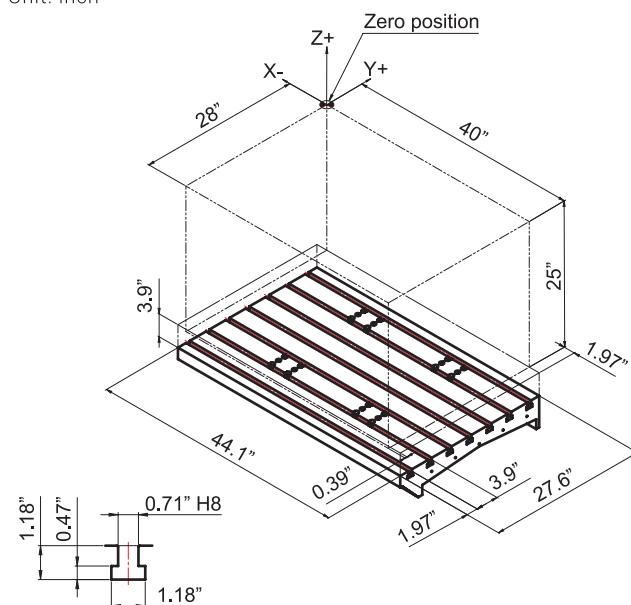

TERA 50V



MACHINE DIMENSIONS

Unit: inch

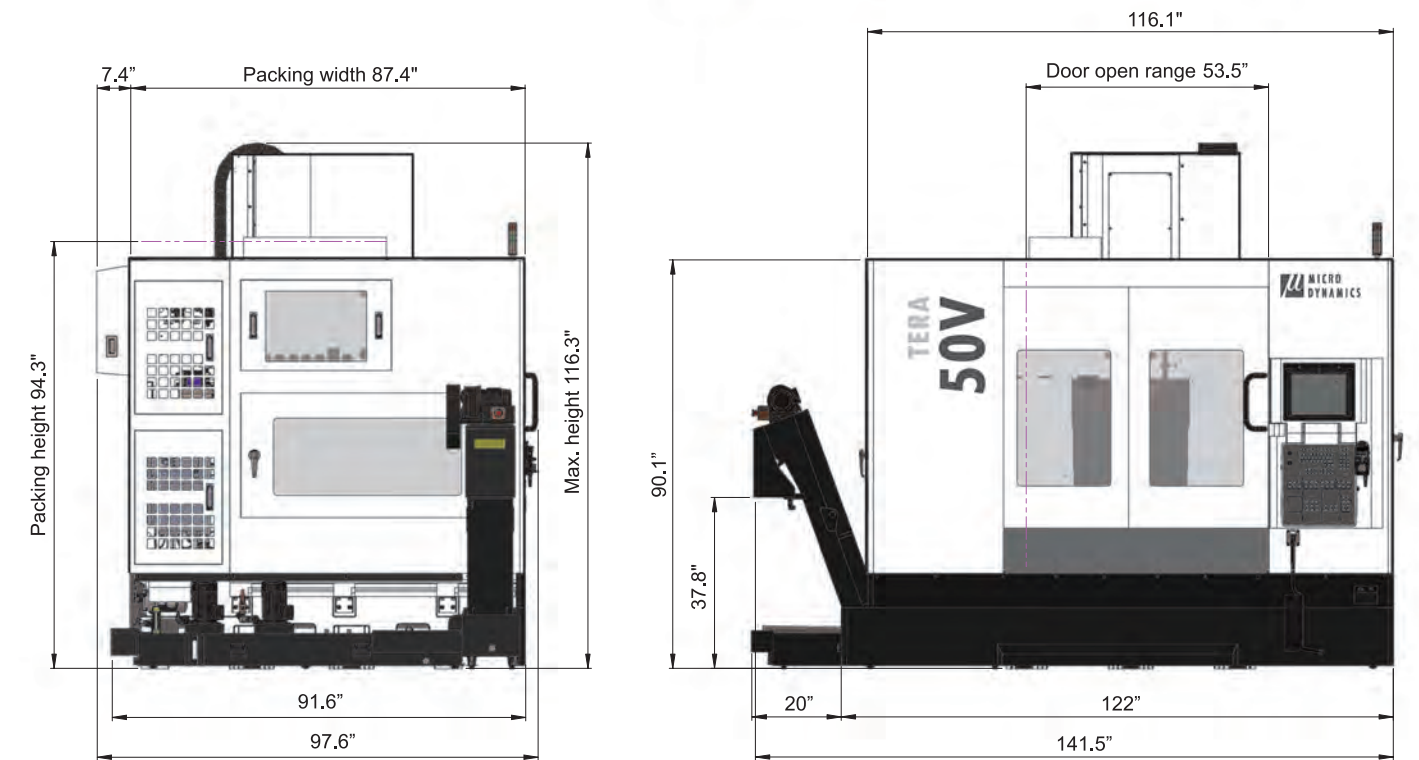

Unit: inch

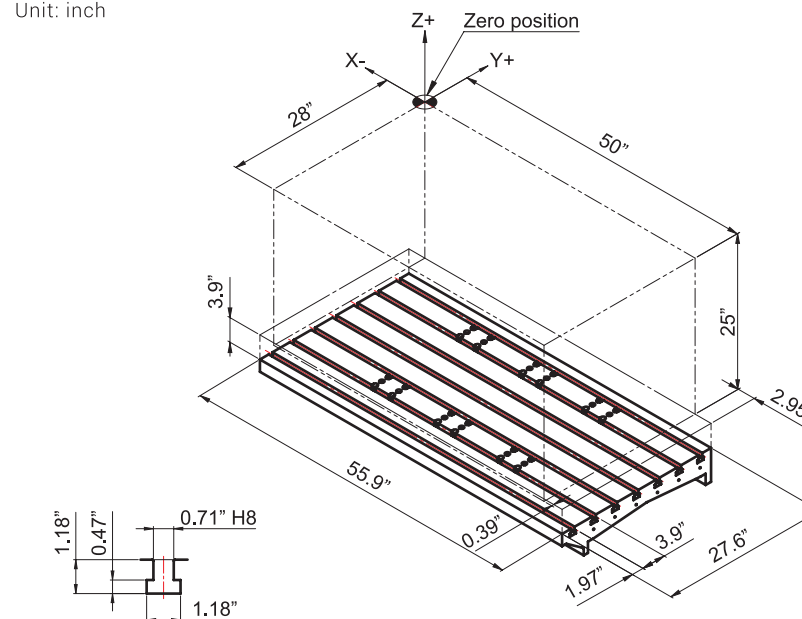

Unit: inch

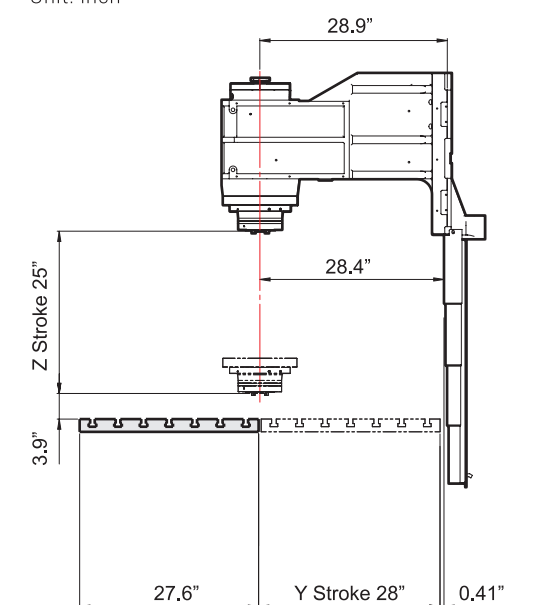

TERA 60V



MACHINE DIMENSIONS

Unit: inch

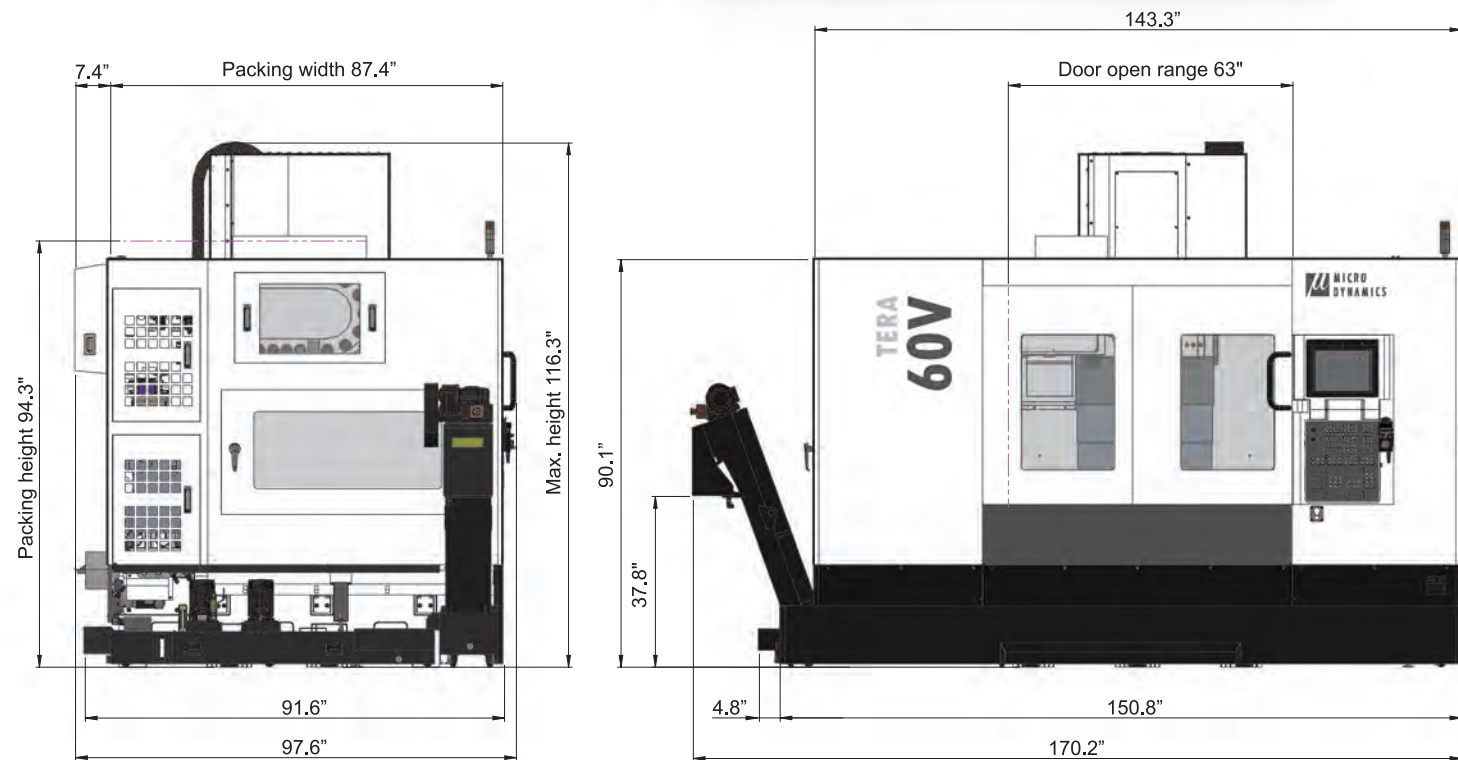

Unit: inch

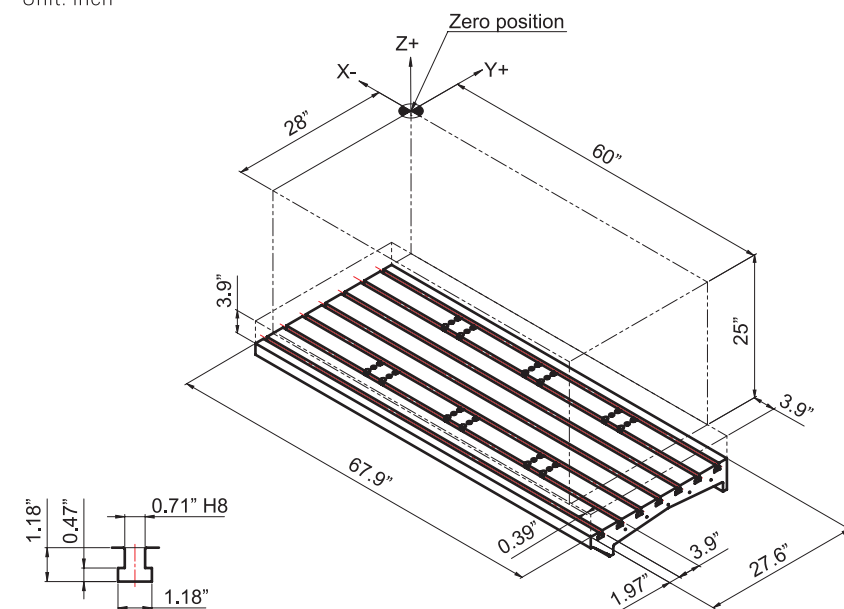

TERA 50VT



MACHINE DIMENSIONS

Unit: inch

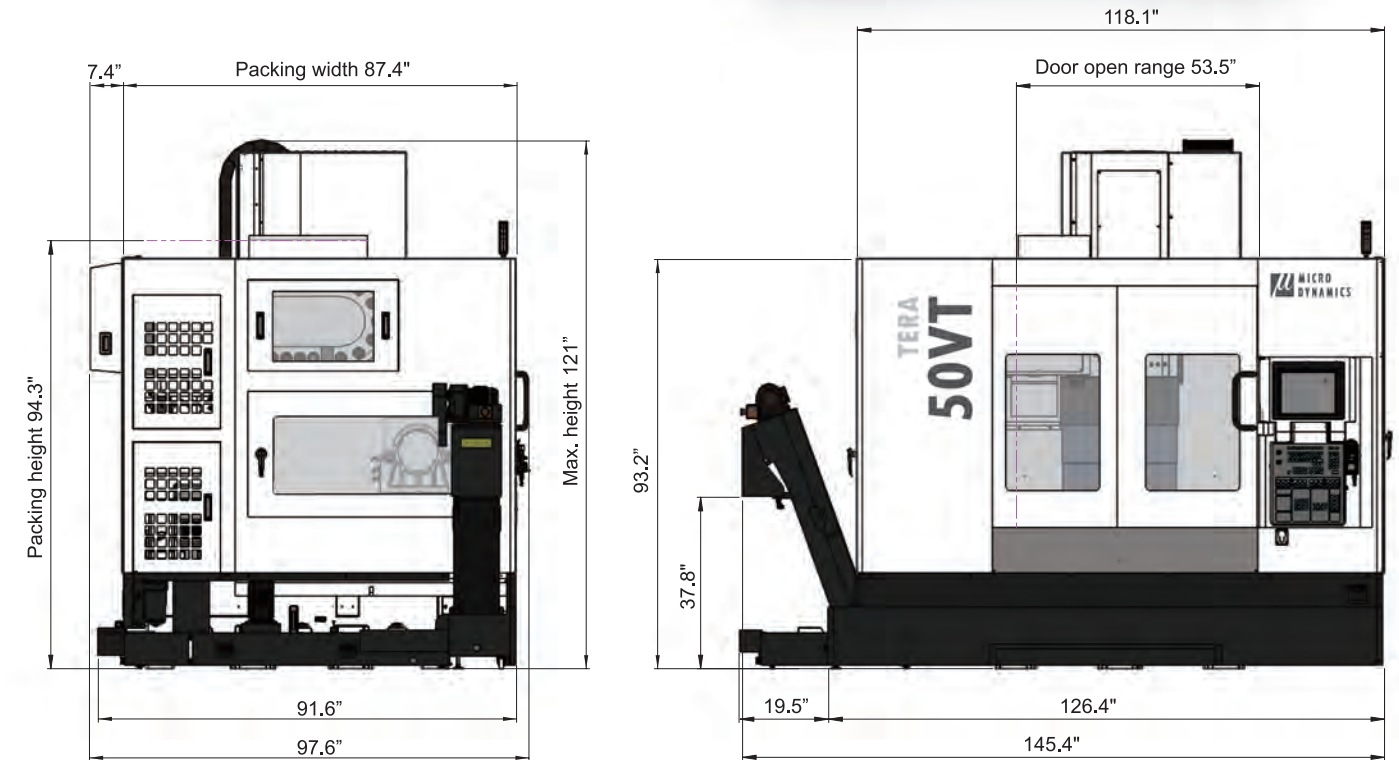

Unit: inch

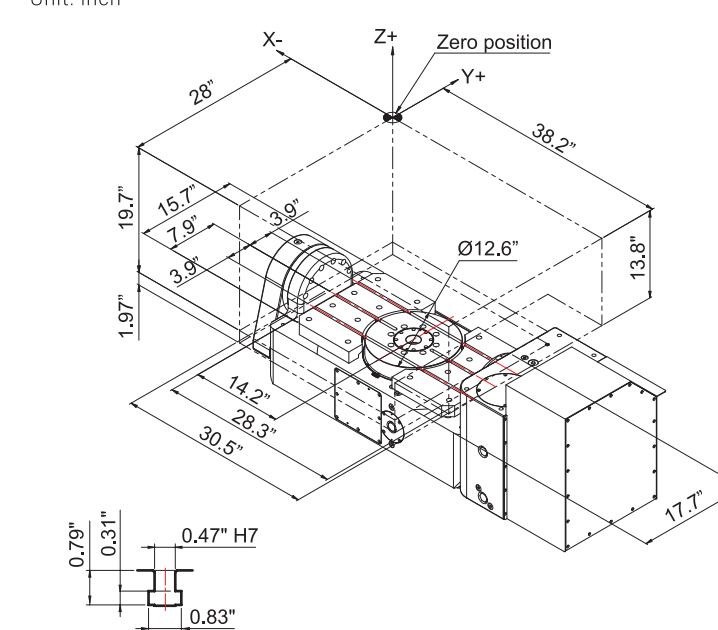

* Ø19.7" and Ø24.8" face plate visit www.microdynamicsfa.com

Unit: inch

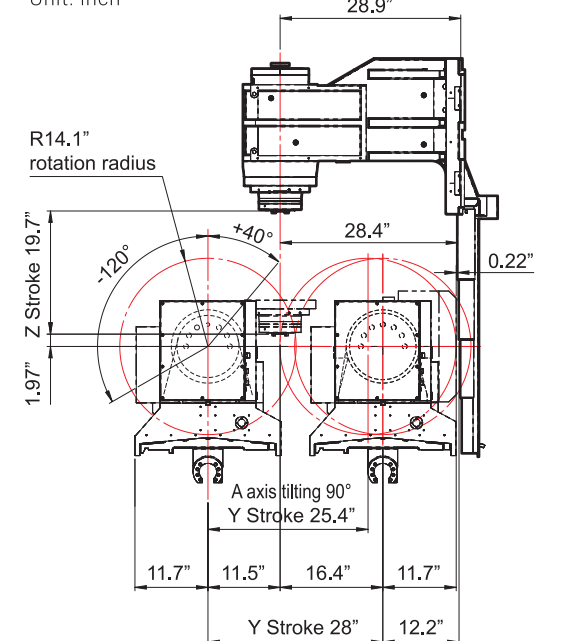

TERA 50V/50



MACHINE DIMENSIONS

Unit: inch

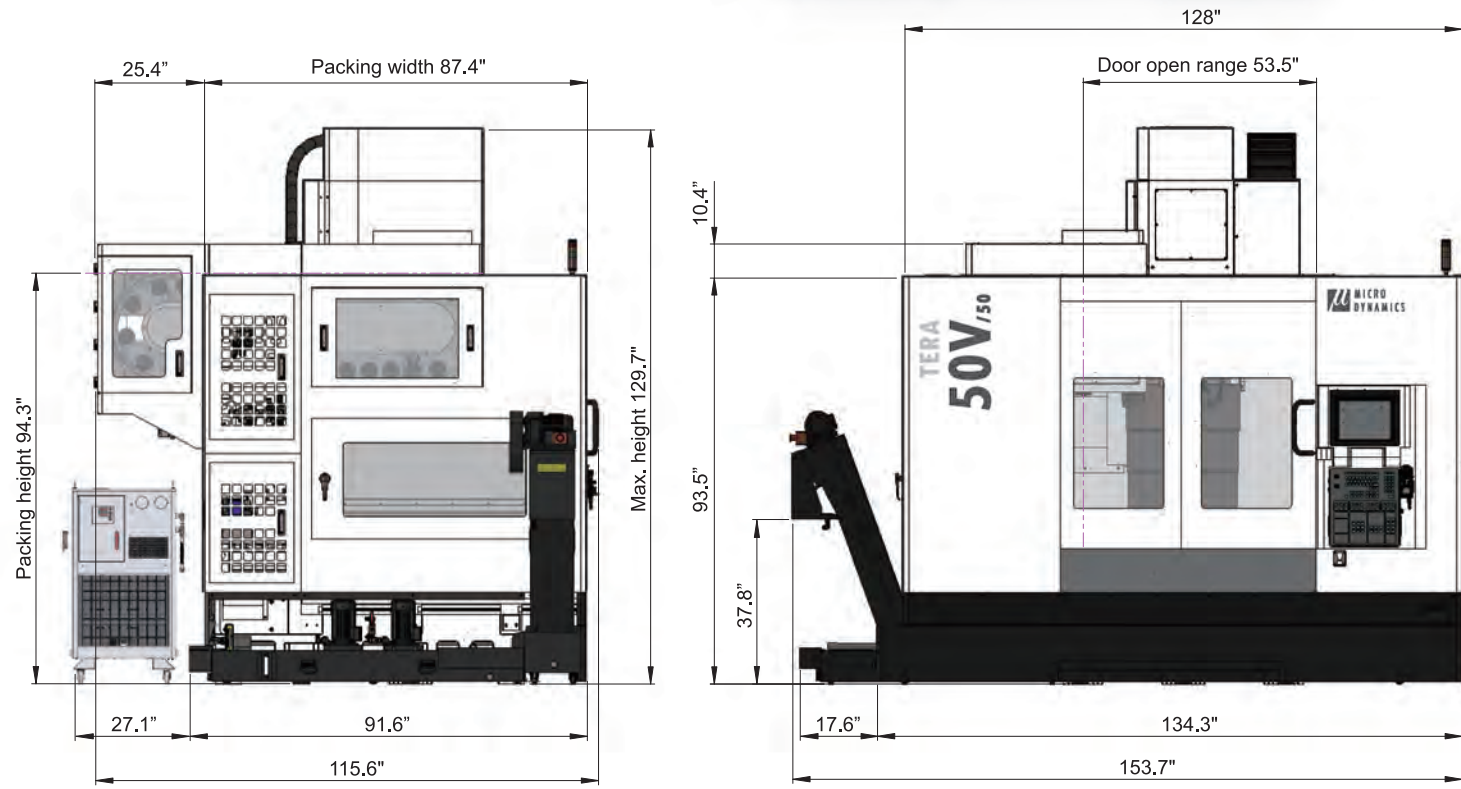

Unit: inch

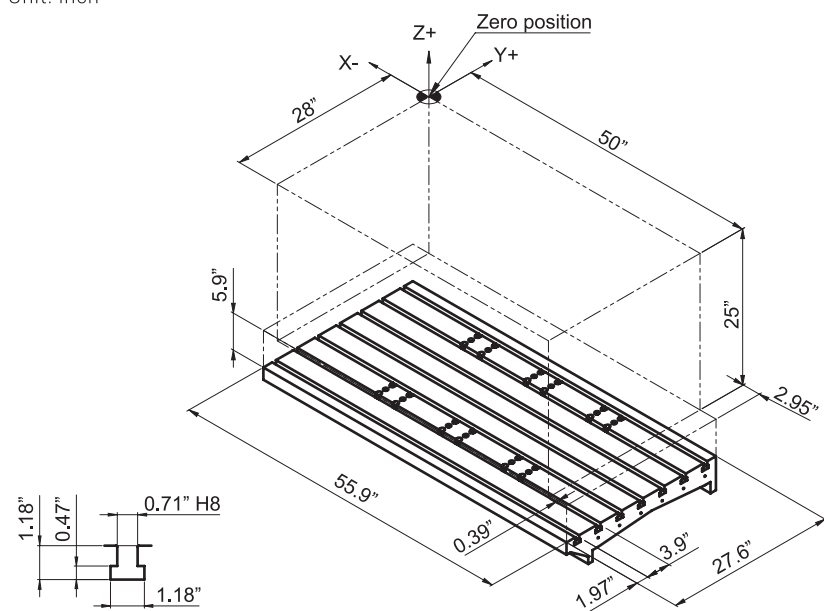

TERA 60V/50

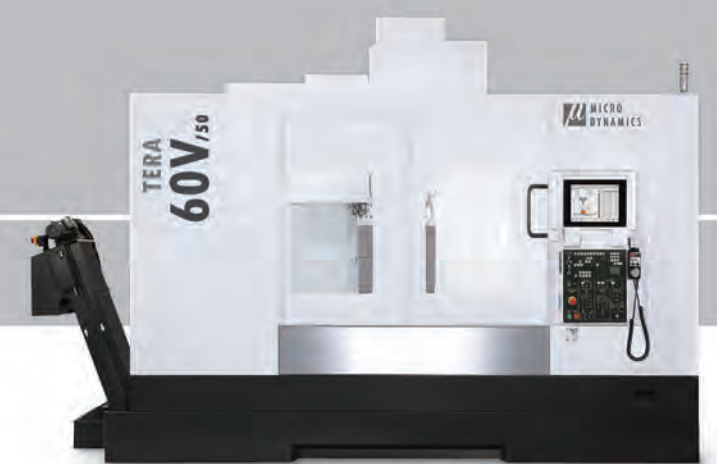

MACHINE DIMENSIONS

Unit: inch

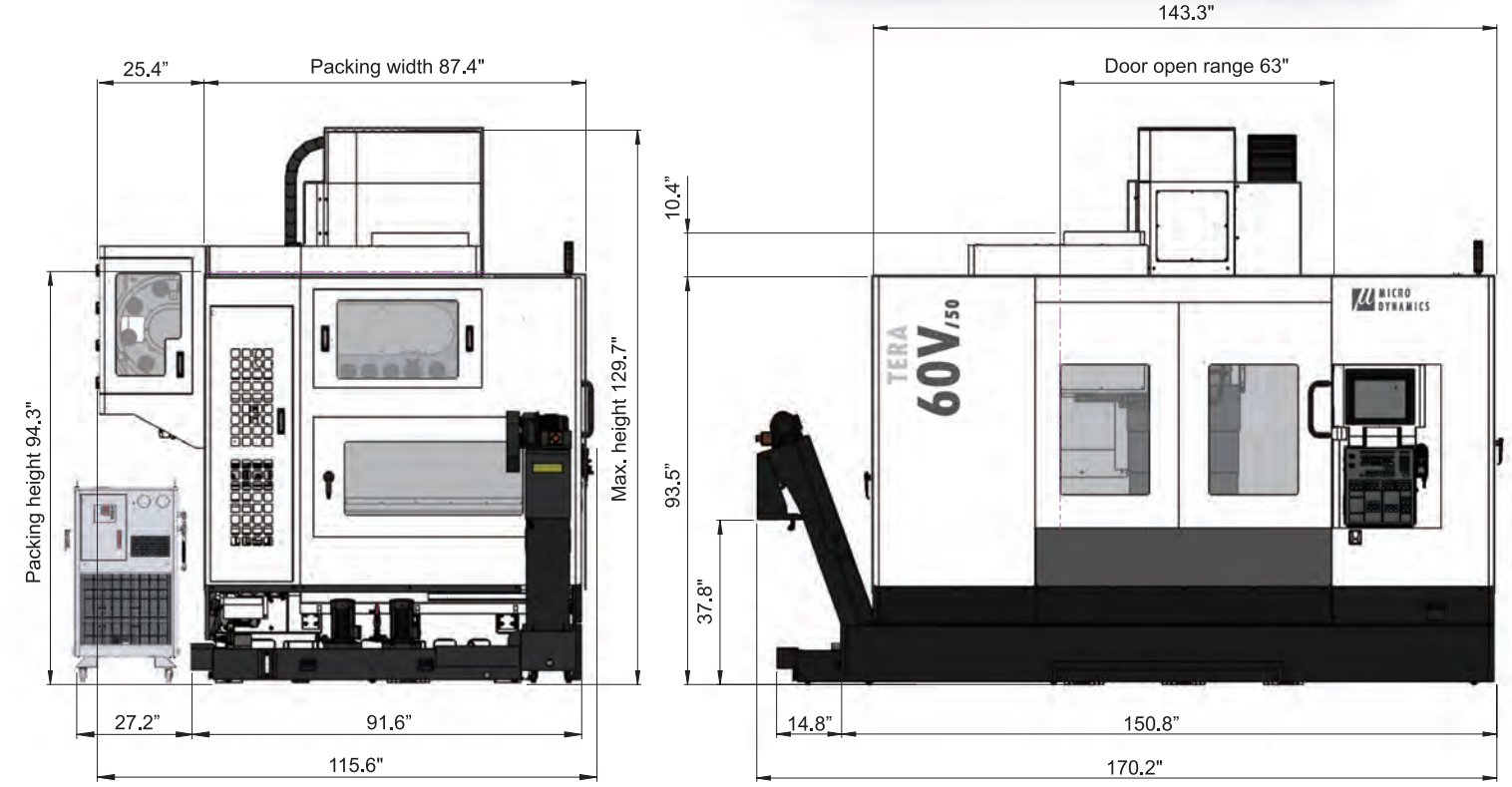

Unit: inch

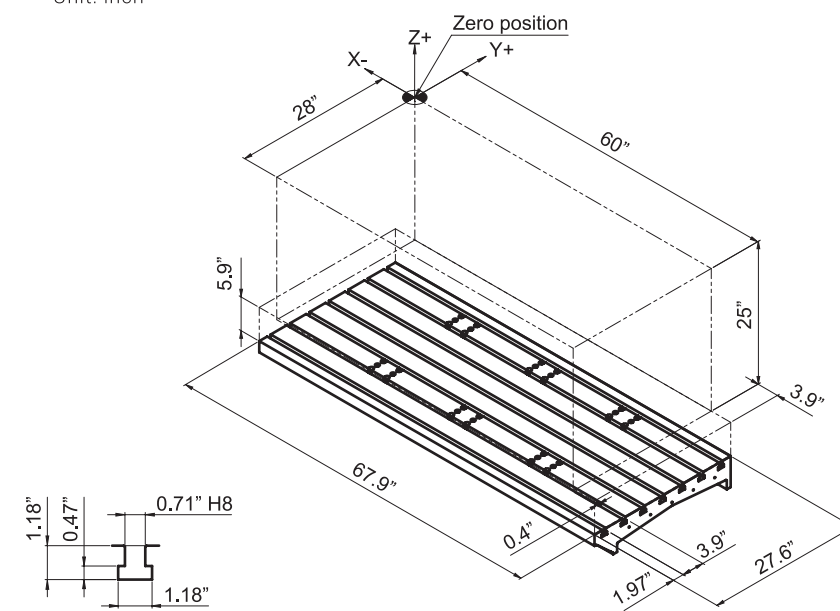

Unit: inch

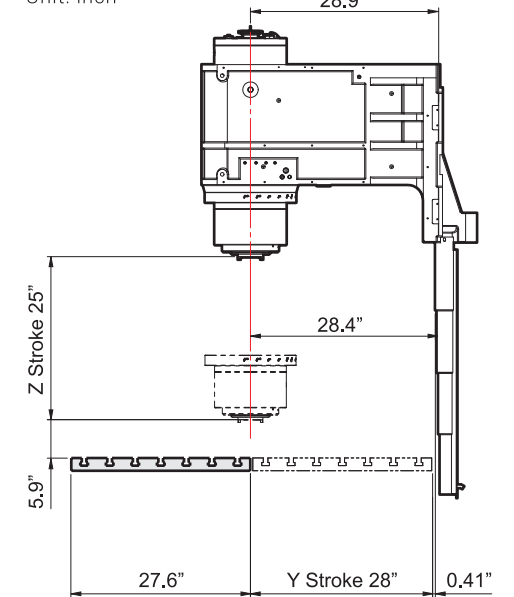

TERA 50VT/50



TOOL SYSTEM

MACHINE DIMENSIONS

Unit: inch

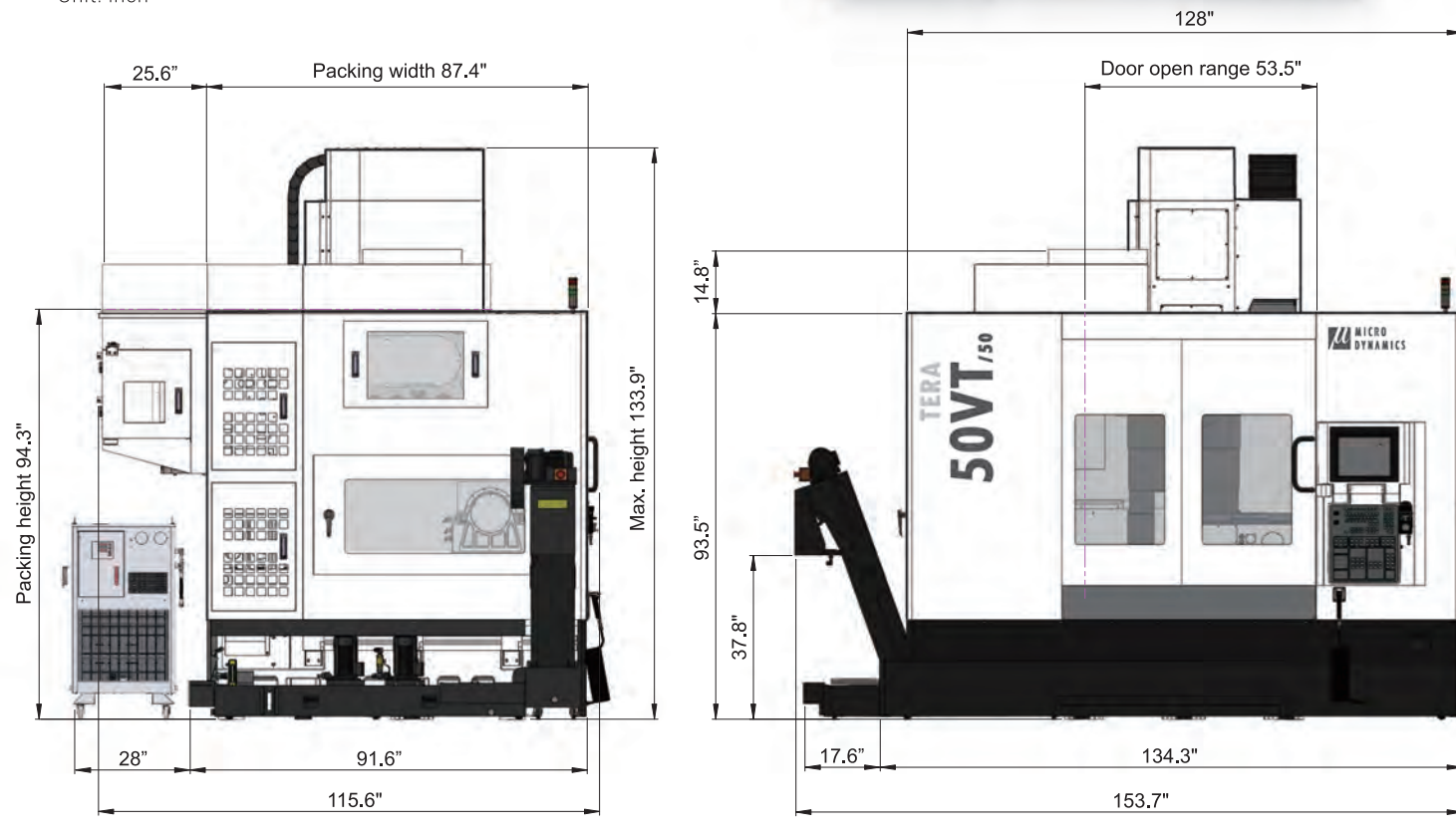

Unit: inch

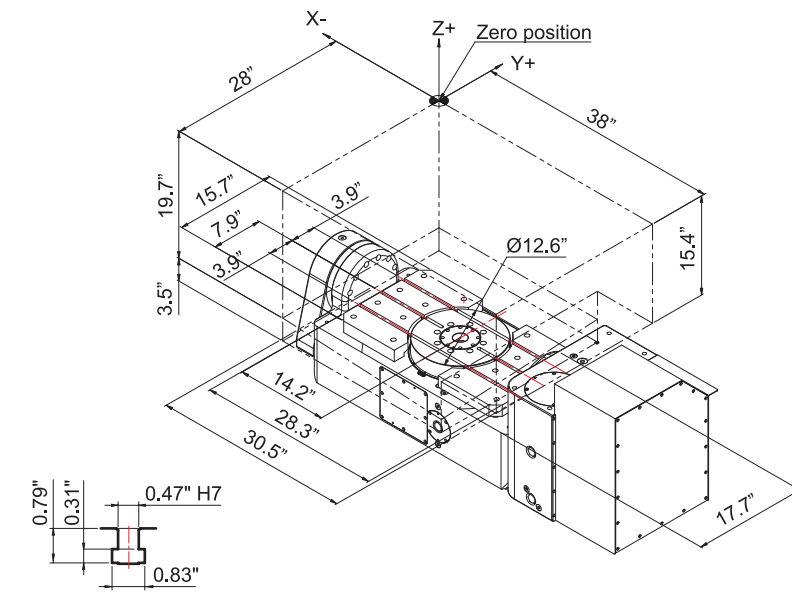

Unit: inch

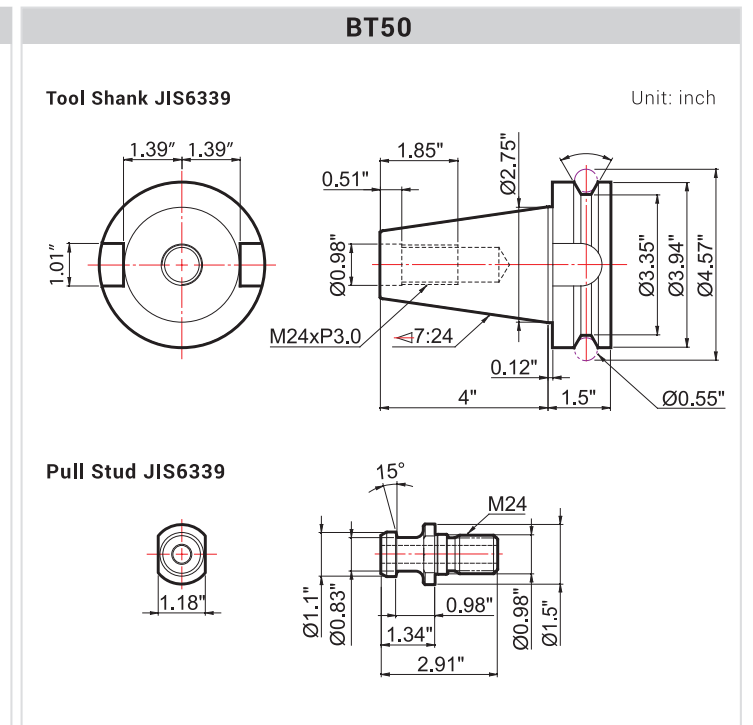
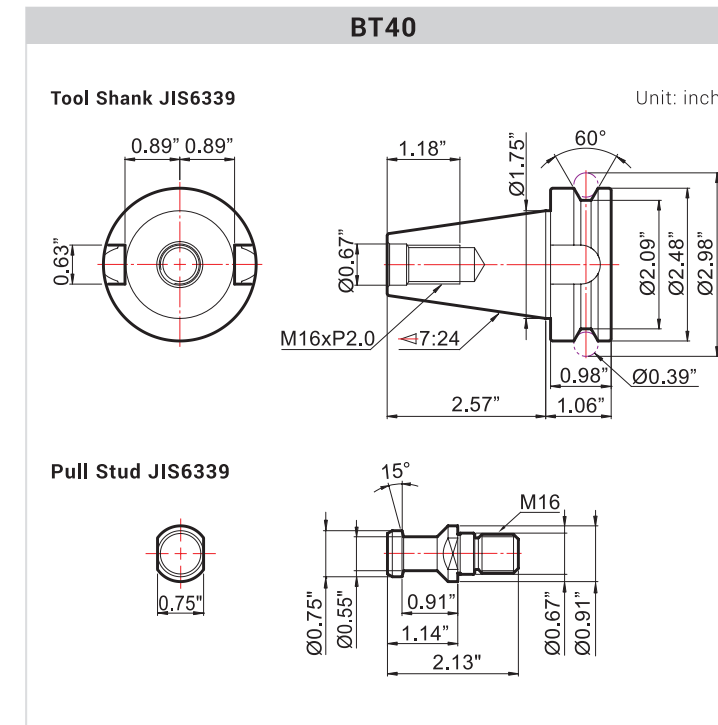
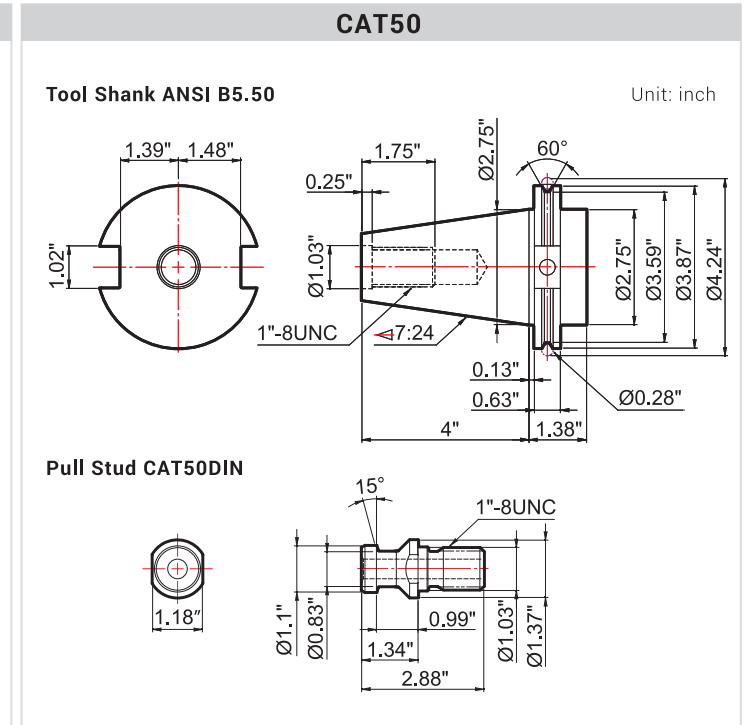
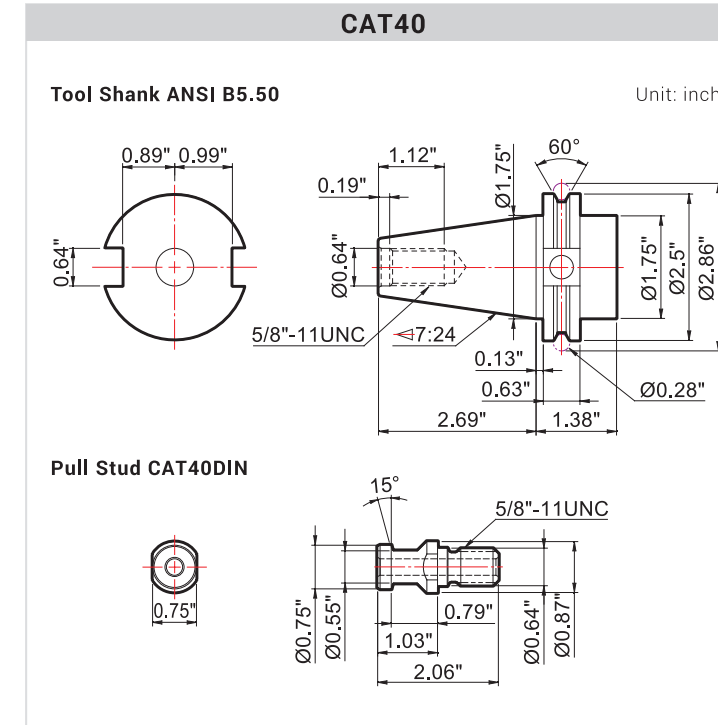
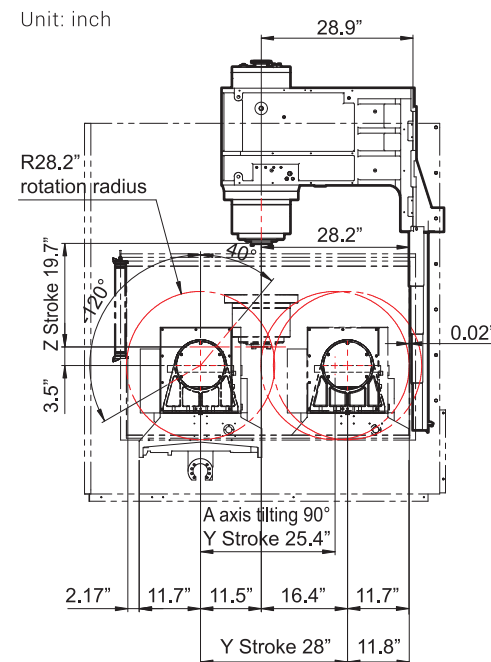

EQUIPMENT

● Standard ○ Option

ITEM / MODEL	MEGA				TERA							
	30V	40V	20VAPC	30VT	40V	50V	60V	50VT	50V _{/50}	60V _{/50}	50VT _{/50}	
Spindle	15,000 rpm Built-In Spindle: 40 Taper	●	●	●	●	●	●	●	●	-	-	-
	20,000 rpm Built-In Spindle: 40 Taper	○	○	○	○	○	○	○	○	-	-	-
	24,000 rpm Built-In Spindle: HSK-63A	○	○	○	○	○	○	○	○	-	-	-
	12,000 rpm Built-In Spindle: 50 Taper	-	-	-	-	-	-	-	-	●	●	●
Accuracy & Scales	DYPEC® Thermal Compensation	●	●	●	●	●	●	●	●	●	●	●
	X / Y / Z Axis Linear Scale	○	○	○	○	○	○	○	○	○	○	○
	A / C Axis Rotary Scale	-	-	-	○	-	-	-	○	-	-	○
Control & HMI	15" Touchscreen Display	●	●	●	●	●	●	●	●	●	●	●
	19" Touchscreen Display	○	○	○	○	○	○	○	○	○	○	○
	Micro Dynamics® HMI	●	●	●	●	●	●	●	●	●	●	●
	Tool Measurement / Workpiece Measurement	○	○	○	○	○	○	○	○	○	○	○
	8 M-Codes (M20 ~ M27)	●	●	●	●	●	●	●	●	●	●	●
	Additional 8 M-Codes (M130 ~ M137)	○	○	○	○	○	○	○	○	○	○	○
	Automatic Power Off	●	●	●	●	●	●	●	●	●	●	●
Tool Magazine	30 Tools ⁽¹⁾ : 40 Taper	●	-	-	-	○	-	-	-	-	-	-
	40 Tools ⁽¹⁾ : 40 Taper	○	●	●	●	●	●	●	●	-	-	-
	60 / 90 / 120 Tools ⁽¹⁾ : 40 Taper	○	○	○	○	○	○	○	○	-	-	-
	32 Tools ⁽¹⁾ : 50 Taper	-	-	-	-	-	-	-	-	●	●	●
	Servo Tool Magazine ⁽¹⁾	○	○	○	○	○	○	○	○	○	○	○
	ATC Auto Door ⁽¹⁾	○	○	○	○	○	○	○	○	○	○	○
	ATC Magazine Panel	○	●	●	●	●	●	●	●	●	●	●
Tool Magazine LED	●	●	●	●	●	●	●	●	●	●	●	
4th / 5th Axis	4th / 5th Axis Pre-wiring	○	○	○	-	○	○	○	-	○	○	-
Coolant & Chip Management	Metal Coolant Ring	○	○	○	○	○	○	○	○	○	○	○
	Spinning Window	○	○	○	○	○	○	○	○	○	○	○
	20-Bar (290 psi) / 40-Bar (580 psi) / 70-Bar (1,000 psi) CTS	○	○	○	○	○	○	○	○	○	○	○
	CTS Preparation (without Rotary Union)	●	●	●	●	●	●	●	●	●	●	●
	Coolant Gun & Air Gun	●	●	●	●	●	●	●	●	●	●	●
	Scraper Type Chip Conveyor	●	●	●	●	●	●	●	●	●	●	●
	Chain Type Chip Conveyor	○	○	○	○	○	○	○	○	○	○	○
	Drum Type Chip Conveyor	○	○	○	○	○	○	○	○	○	○	○
	Rear Type Chip Conveyor ⁽¹⁾	○	○	○	○	○	○	○	○	○	○	○
	Twin Chip Augers	●	●	●	●	●	●	●	●	●	●	●
	Disc Type Oil Skimmer	○	○	○	○	○	○	○	○	○	○	○
Oil Mist Collector	○	○	○	○	○	○	○	○	○	○	○	
Column Riser	MEGA series 3.9" / 5.9" / 9.8" ⁽²⁾	○	○	○	○	-	-	-	-	-	-	-
	TERA series 4.7" ⁽³⁾	-	-	-	-	○	○	○	-	-	-	-
Face Plate	11.8" / 13.8" Diameter Face Table	-	-	-	○	-	-	-	-	-	-	-
	19.7" / 24.8" Diameter Face Table	-	-	-	-	-	-	-	○	-	-	○
Safety & Power	CE-Conformity Package	○	○	○	○	○	○	○	○	○	○	○
	Transformer	○	○	○	○	○	○	○	○	○	○	○
Automation	Automatic Door (Pneumatic / Servo)	○	○	○	○	○	○	○	○	○	○	
Others	Full Chip Enclosure	●	●	●	●	●	●	●	●	●	●	●
	Safety Door	●	●	●	●	●	●	●	●	●	●	●
	Manuals / Tool Kit / Foundation Kit	●	●	●	●	●	●	●	●	●	●	●

⁽¹⁾ Factory order ⁽²⁾ MEGA 20VAPC standard is 3.9". MEGA 30VT standard is 5.9". ⁽³⁾ TERA 50VT standard is 4.7". TERA 50V_{/50}, TERA 60V_{/50} standard is 5.9". TERA 50VT_{/50} standard is 10.1".

SPECIFICATIONS

SERIES		MEGA series				TERA series							
ITEM / MODEL	UNIT	MEGA 30V	MEGA 40V	MEGA 20VAPC	MEGA 30VT	TERA 40V	TERA 50V	TERA 60V	TERA 50VT	TERA 50V _{/50}	TERA 60V _{/50}	TERA 50VT _{/50}	
TRAVEL													
X Axis	inch	30	40	24	30	40	50	60	38	50	60	38	
Y Axis	inch	20	20	20	20	28	28	28	28 / 25.4 (90°)	28	28	28 / 25.4 (90°)	
Z Axis	inch	20	20	20	17.4	25	25	25	19.7	25	25	19.7	
A Axis (Tilting Axis)	deg	N/A		40° ~ -120°		N/A		40° ~ -120°		N/A		40° ~ -120°	
C Axis (Rotary Axis)	deg	N/A		360°		N/A		360°		N/A		360°	
Spindle Nose to Table Surface	inch	3.9 ~ 24	3.9 ~ 24	3.5 ~ 23.6	1.97 ~ 19.3	3.9 ~ 29	3.9 ~ 29	3.9 ~ 29	1.97 ~ 21.7	5.9 ~ 30.9	5.9 ~ 30.9	3.5 ~ 23.2	
Spindle Center to Column Front	inch	21.7	21.7	21.7	21.7	28.9	28.9	28.9	28.9	28.9	28.9	28.9	
TABLE													
Table Size	inch	33.9 × 19.7	44.1 × 19.7	22 × 15.7	Ø8.7 (19.7 × 11.8)	44.1 × 27.6	55.9 × 27.6	67.9 × 27.6	Ø12.6 (28.3 × 15.7)	55.9 × 27.6	67.9 × 27.6	Ø12.6 (28.3 × 15.7)	
Min. Table Index Unit	deg	N/A		0.001°		N/A		0.001°		N/A		0.001°	
Max. Table Load	lb	1,764	2,205	441 × 2	331	3,307	3,307	4,409	661	3,307	4,409	661	
Table Height (from the Ground)	inch	33.1	33.1	37.4	43.6	35.4	35.4	35.4	47.4	35.4	35.4	47.4	
SPINDLE													
Spindle Taper		40 Taper Dual Contact (CAT / BT / HSK-63A)				40 Taper Dual Contact (CAT / BT / HSK-63A)				50 Taper Dual Contact (CAT / BT / HSK-100A)			
I.D. of Spindle Bearing	inch	Ø2.75				Ø2.75				Ø3.93			
Spindle Speed	rpm	50 ~ 15,000				50 ~ 15,000				50 ~ 12,000			
Max. Power	hp	41				41				45			
Max. Cutting Torque	ft-lb	104				104				420			
Clamping Force	lbf	2,646				2,646				4,630			
Max. Speed for Rigid Tapping	rpm	6,000				6,000				3,000			
FEEDRATE													
Rapid Feedrate - X Axis	ipm	2,047	2,047	2,047	1,889	2,047	2,047	2,047	1,889	2,047	2,047	1,889	
Rapid Feedrate - Y Axis	ipm	2,047	2,047	2,047	1,889	2,047	2,047	2,047	1,889	2,047	2,047	1,889	
Rapid Feedrate - Z Axis	ipm	1,889	1,889	1,889	1,889	1,889	1,889	1,889	1,889	1,260	1,260	1,260	
Rapid Feedrate - A (Tilting) Axis	rpm	N/A		25		N/A		33		N/A		33	
Rapid Feedrate - C (Rotary) Axis	rpm	N/A		33		N/A		66		N/A		66	
Cutting Feedrate	ipm	0 ~ 787				0 ~ 787				0 ~ 787			
ATC													
Magazine Capacity		30	40			40			32				
Tool Selection		Bi-Direction / Random				Bi-Direction / Random				Bi-Direction / Random			
Tool Shank Type		ANSI B5.50 (CAT40) / JIS6339 (BT40)				ANSI B5.50 (CAT40) / JIS6339 (BT40)				ANSI B5.50 (CAT50) / JIS6339 (BT50)			
Pull Stud Type		CAT40DIN / JIS6339				CAT40DIN / JIS6339				CAT50DIN / JIS6339			
Max. Tool Diameter x Length	inch	Ø3 × 9.1	Ø3 × 11.8	Ø3 × 9.4	Ø3 × 11.8	Ø3 × 10.2	Ø3 × 11.8	Ø3 × 11.8	Ø3 × 11.8	Ø5 × 13.8	Ø5 × 13.8	Ø5 × 13.8	
Without Adjacent Tool	inch	Ø5.9				Ø5.9				Ø9			
Max. Tool Weight	lb	15.4				15.4				33.1			
PERIPHERAL													
Power Consumption (220V/3PH)	KVA	30				40			50		55		
Pneumatic Supply	cfm	10.6				10.6			10.6		10.6		
Cutting Coolant Pump Motor	hp	1.5				1.5			1.5		1.5		
Base Wash Pump Motor	hp	1.5				1.5			1.5		1.5		
CTS Pump Motor (opt)	hp	4				4			4		4		
Coolant Tank Capacity	gal	66	79	79	79	79	106	106	106	92	106	92	
Foot Print Size (W x D)	inch	94.1 × 88.4	119.8 × 90.3	100.8 × 117	119.8 × 90.3	123.5 × 97.6	142 × 97.6	170.2 × 97.6	145.4 × 97.6	153.7 × 115.6	170.2 × 115.6	153.7 × 115.6	
Machine Height (H)	inch	111.1	111.1	115	117.1	116.3	116.3	116.3	121	129.7	129.7	133.9	
Packing Size (W x D x H)	inch	108.3 × 90.6 × 100.4	129.9 × 90.9 × 100.4	126 × 86.6 × 100.4	129.9 × 90.9 × 100.4	133.9 × 90.9 × 100.4	161.4 × 90.9 × 100.4	192.9 × 90.9 × 100.4	133.9 × 90.6 × 100.4	161.4 × 90.9 × 100.4	192.9 × 90.9 × 100.4	161.4 × 90.9 × 106.3	
Machine Net Weight	lb	10,780	12,368	14,109	13,999	17,725	18,960	20,216	21,076	21,164	22,421	23,369	
Machine Gross Weight	lb	11,177	12,897	14,793	14,528	18,254	19,599	21,076	21,848	21,803	23,281	24,052	
ACCURACY													
Positioning Accuracy / Full Stroke	inch	0.0002 (VDI 3441)				0.0002 (VDI 3441)				0.0002 (VDI 3441)			
Repeatability Accuracy	inch	±0.0001				±0.0001				±0.0001			

Note: Specifications subject to change without notice.